

21697B, 21697B-E

INDUSTRIAL FINE WIRE STAPLER

GRAPADORA INDUSTRIAL DE ALAMBRE FINO

AGRAFEUSE INDUSTRIELLE À AGRAFES FINES

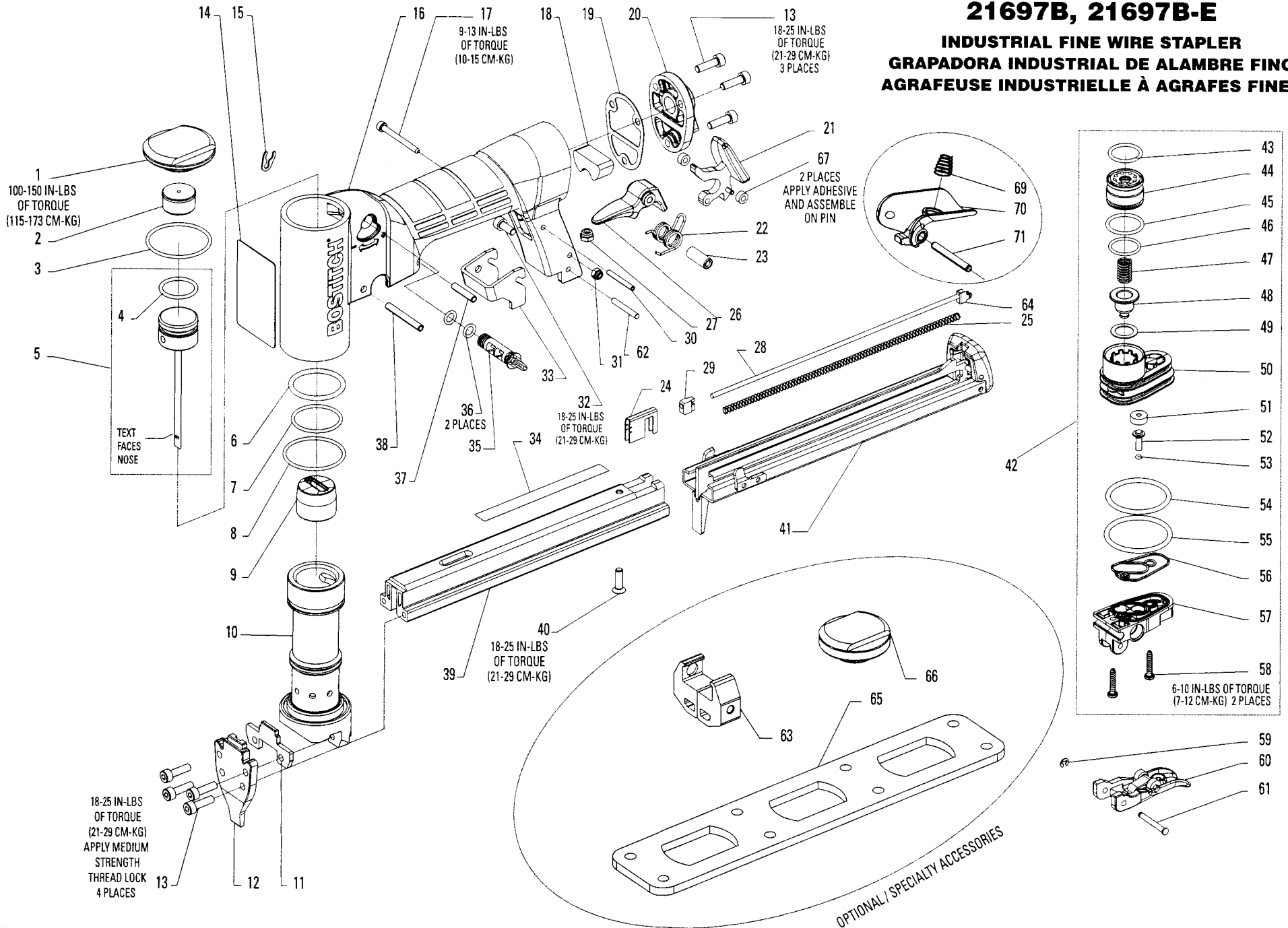

IP1251-1REVA 04/07

TO BE USED WITH PARTS LIST IP1251-2 AND OPERATION AND MAINTENANCE MANUAL 174325.

BOSTITCH

21697B, 21697B-E			Parts List:		IP1251-2REVA
To be Used with tool parts illustration:			IP1251-1REVA		
and operation and maintenance manual:			174325		
Serial Number on the Tool:			21697B		72130001 and Higher
			21697B-E		000 and Higher
ITEM	PART #	DESCRIPTION	ITEM	PART #	DESCRIPTION
1	174288	CAP	54	108467	O-RING, 1.237 X .103
2	174289	BUMPER, PISTON STOP	55	100817	O-RING, 1.299 X .103
3	100353	O-RING, 1.301 X .070	56	174284	SEAL, VALVE
4	174308	O-RING,.701X.075	57	174276	HOUSING, TRIGGER
5	177718	ASSEMBLY, DRIVER/PISTON	58	174285	SCREW, M3 X 16
6	174309	O-RING, 1.049X.103	59	174298	RETAINER,E-RING
7	174310	O-RING,.989X.070	60	174269	ASSEMBLY, TRIGGER
8	851349	O-RING, 1.239 X .070	61	174268	PIN, SPECIAL
9	174100	BUMPER	62	174326	PIN,SOLID,M3X22
10	174098	SLEEVE, CYLINDER			
11	174099	PLATE, DRIVER GUIDE	64	177739	SEAT,SPRING GUIDE
12	177703	NOSE			
13	174306	SCREW,SHCS,M4X0.7X14	67	177742	BUSHING
14	159831	LABEL, WARNING			
15	174290	RETAINER, CLIP	21697B-E (EUROPEAN TOOL) ONLY		
16	174265	FRAME	69	174300	SPRING, COMPRESSION, CONICAL
17	174274	SCREW,SHCS.M3X0.5X32	70	174299	TRIGGER, SECOND
18	174266	MUFFLER	71	177685	PIN, SPRING, 4X30MM
19	174295	GASKET, END CAP			
20	174296	CAP, END	ACCESSORIES (SOLD SEPARATELY)		
21	174273	LATCH	63	174267	ASSEMBLY, SKIRT GAUGE
22	174301	SPRING, TORSION			
23	174302	BUSHING, SPRING	65	174322	WRENCH
24	177725	PUSHER	66	174323	CAP, HEAVY
25	177736	SPRING, COMPRESSION			
26	174297	LATCH, INSIDE	69	174300	SPRING, COMPRESSION, CONICAL
27	MHE4070-100	ELASTIC STOP NUT, M4	70	174299	TRIGGER, SECOND
28	177738	GUIDE,SPRING	71	177685	PIN, SPRING, 4X32MM
29	177737	BLOCK,PUSHER			
30	174303	PIN,COILED,M3X22			
31	MHE3050-100	NUT, NYLON , M3 x 0.5			
32	MSC4070-10	SCREW, SHCS, M4X0.70X10			
33	174264	STOP PLATE			
34	174318	LABEL, 21697B			
35	174287	VALVE, ENERGY CONTROL			
36	174311	O-RING,.217X.059			
37	174304	PIN,COILED,M4X18			
38	174305	PIN,COILED,M4X30			
39	177732	MAGAZINE			
40	174307	SCREW,SFHCS,M4X0.7X14			
41	177711	ASSEMBLY, SLIDING MAGAZINE			
42	TVA13	ASSEMBLY, TRIGGER VALVE			
43	86459	O-RING, .614 X .070			
44	174278	HEAD VALVE			
45	174312	O-RING, .700X.072			
46	102163	O-RING, .591 X .059			
47	174280	SPRING, COMPRESSION			
48	174279	SEAL, EXHAUST			
49	174281	WASHER, SPECIAL			
50	174277	HOUSING, HEAD VALVE			
51	174282	SEAL, TRIGGER STEM			
52	174283	STEM			
53	174313	O-RING,.042X.050			