

# 21684B, 21684B-E 21684-EXP

**INDUSTRIAL FINE WIRE STAPLER**  
**GRAPADORA INDUSTRIAL DE ALAMBRE FINO**  
**AGRAFEUSE INDUSTRIELLE À AGRAFES FINES**

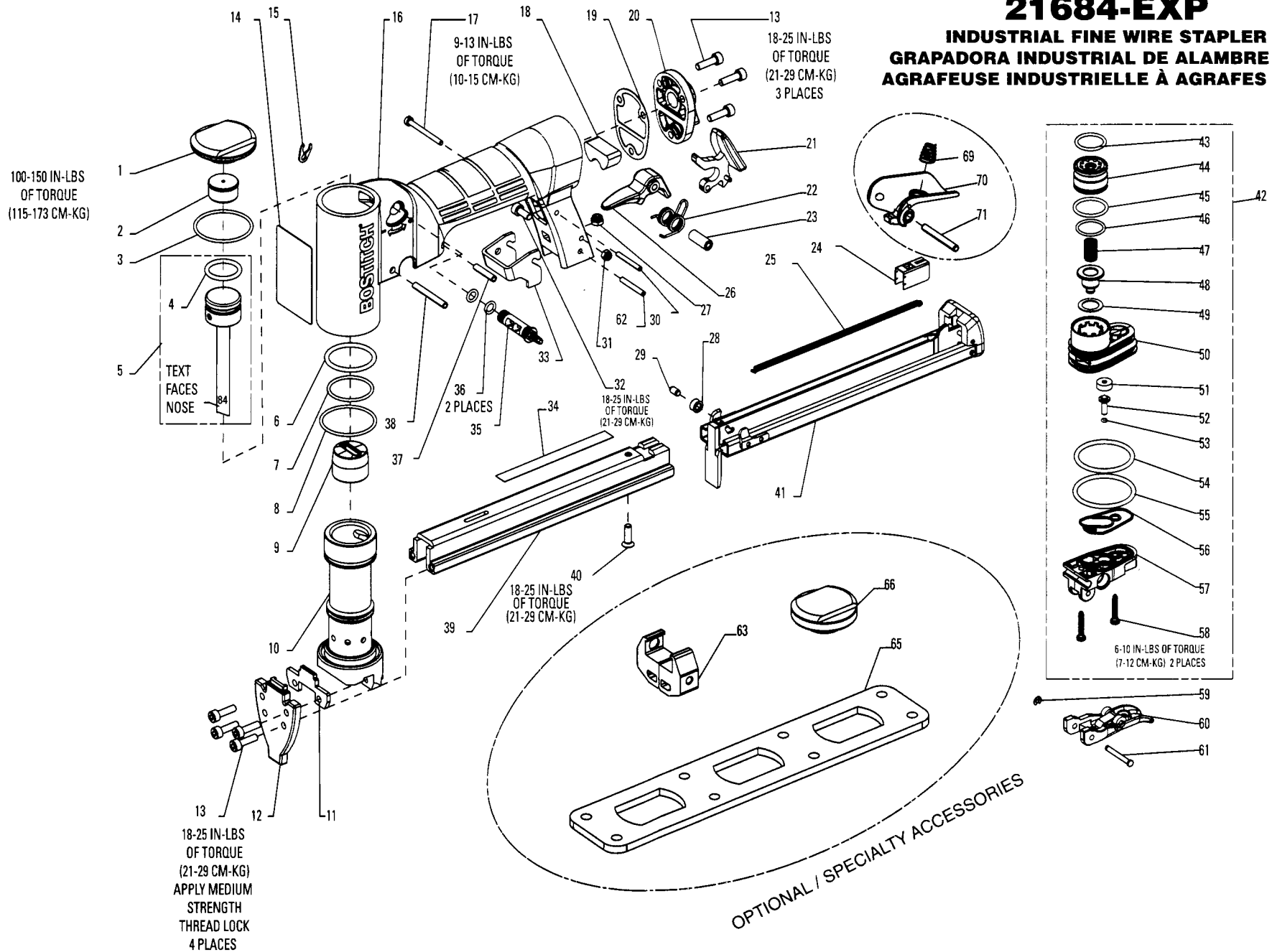

**BOSTITCH**

21684B, 21684B-E, 21684-EXP			Parts List:		IP1250-2REVA
<b>To be Used with tool parts illustration:</b>					IP1250-1REVA
<b>and operation and maintenance manual:</b>					174325
<b>Serial Number on the Tool:</b>					
					21684B 71500001 and Higher
					21684B-E 000 and Higher
					21684-EXP 000 and Higher
ITEM	PART #	DESCRIPTION	ITEM	PART #	DESCRIPTION
1	174288	CAP	54	108467	O-RING,1.237 X .103
2	174289	BUMPER, PISTON STOP	55	100817	O-RING, 1.299 X .103
3	100353	O-RING, 1.301 X .070	56	174284	SEAL, VALVE
4	174308	O-RING,.701X.075	57	174276	HOUSING, TRIGGER
5	177717	ASSEMBLY, DRIVER/PISTON	58	174285	SCREW, M3 X 16
6	174309	O-RING,1.049X.103	59	174298	RETAINER,E-RING
7	174310	O-RING,.989X.070	60	174269	ASSEMBLY, TRIGGER
8	851349	O-RING, 1.239 X .070	61	174268	PIN, SPECIAL
9	174100	BUMPER	62	174326	PIN,SOLID,M3X22
10	174098	SLEEVE, CYLINDER			
11	174099	PLATE, DRIVER GUIDE	<b>21684B-E, 21684-EXP (EUROPEAN TOOLS) ONLY</b>		
12	177702	NOSE	69	174300	SPRING, COMPRESSION, CONICAL
13	174306	SCREW,SHCS,M4X0.7X14	70	174299	TRIGGER, SECOND
14	159831	LABEL, WARNING	71	177685	PIN, SPRING, 4X30MM
15	174290	RETAINER, CLIP			
16	174265	FRAME	<b>ACCESSORIES (SOLD SEPARATELY)</b>		
17	174274	SCREW,SHCS,M3X0.5X32	63	174267	ASSEMBLY, SKIRT GAUGE
18	174266	MUFFLER			
19	174295	GASKET, END CAP	65	174322	WRENCH
20	174296	CAP, END	66	174323	CAP, HEAVY
21	174273	LATCH			
22	174301	SPRING, TORSION	69	174300	SPRING, COMPRESSION, CONICAL
23	174302	BUSHING, SPRING	70	174299	TRIGGER, SECOND
24	177724	PUSHER	71	177685	PIN, SPRING, 4X32MM
25	174291	SPRING, EXTENSION			
26	174297	LATCH, INSIDE	<b>21684-EXP (EUROPEAN TOOL) ONLY</b>		
27	MHE4070-100	ELASTIC STOP NUT, M4	72	177713	ASSEMBLY, DRIVER/PISTON
28	174293	ROLLER			
29	177741	PIN, ROLLER			
30	174303	PIN,COILED,M3X22			
31	MHE3050-100	NUT, NYLON , M3 x 0.5			
32	MSC4070-10	SCREW, SHCS, M4X0.70X10			
33	174264	STOP PLATE			
34	174319	LABEL, 21684B			
35	174287	VALVE, ENERGY CONTROL			
36	174311	O-RING, 217X.059			
37	174304	PIN,COILED,M4X18			
38	174305	PIN,COILED,M4X30			
39	177731	MAGAZINE			
40	174307	SCREW,SFHCS,M4X0.7X14			
41	177710	ASSEMBLY, SLIDING MAGAZINE			
42	TVA13	ASSEMBLY, TRIGGER VALVE			
43	86459	O-RING, .614 X .070			
44	174278	HEAD VALVE			
45	174312	O-RING,.700X.072			
46	102163	O-RING, .591 X .059			
47	174280	SPRING, COMPRESSION			
48	174279	SEAL, EXHAUST			
49	174281	WASHER, SPECIAL			
50	174277	HOUSING, HEAD VALVE			
51	174282	SEAL, TRIGGER STEM			
52	174283	STEM			
53	174313	O-RING,.042X.050			