

<b>Rapid</b> 		<b>SPARE PARTS LIST</b>				
Reg. By <b>kele</b>	Appr. By <b>peto</b>	Appr. Date 2002-05-17	Page 1(14)	Class <b>053</b>	No. <b>197798</b>	Rev. <b>07</b>
Info		Product name <b>RAPID 105-106</b>				

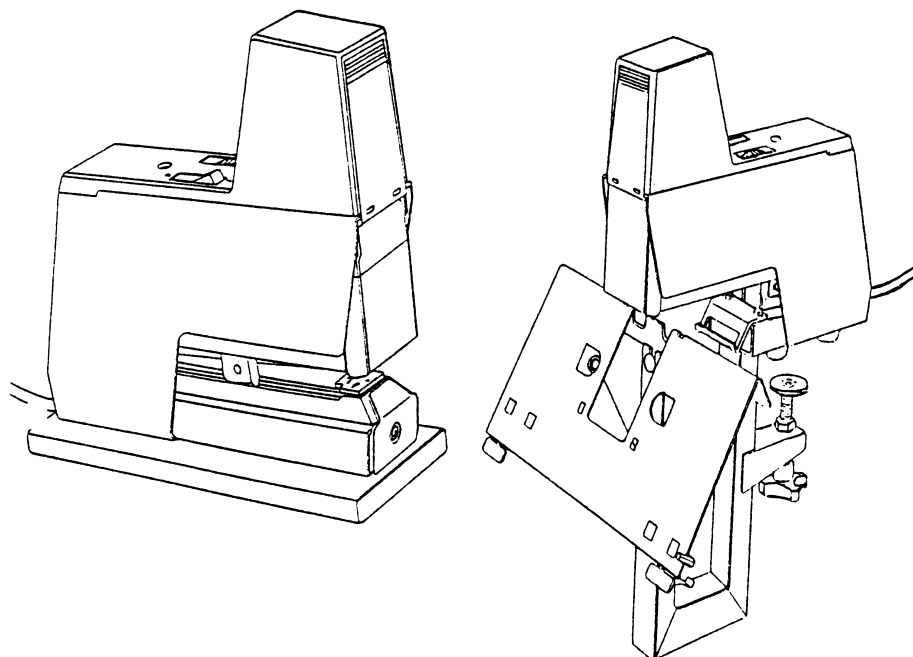

\* No spare part

\*\* Extra accessory spare part

Pos No	Part No	Part Name	Qty
1	17786501	Top cover 105	1
1	17786502	Top cover 106	1
2C-1	17781601	Magnet unit 220V-230V, 50Hz	1
2C-2	17781602	Magnet unit 115V, 60Hz	1
2C-3	17781603	Magnet unit 240V, 50Hz	1
2C-4	17781604	Magnet unit 100V, 60Hz	1
2C=2:1-2:7			
2:1*		Coil	1
2:2*		Protecting shield	1
2:3*		Protecting shield	1
2:4*		Magnet housing	1
2:5	177667	Piston complete	1
2:6	177774	Piston guide	1
2:7	177782	Damper	1
3:1	133082	Washer	1
3:2	155101	Lock washer	1
4	156489	Cord clamp (earth point)	1
5	167033	Screw	105=11 106=10
6	177873	Rear cover plate	1
7	177857	Cable clamp	1
8	167044	Screw	2

*When ordering always state then part numbers*

**Head office and factory: ISABERG RAPID AB, Box 115, S-330 27 Hestra, Sweden**

**Telephone 46-(0)370-33 95 00. Telefax 46-(0)370-33 95 02.**

**Internet [www.isaberg-rapid.com](http://www.isaberg-rapid.com)**

<b>Rapid</b> 		<b>SPARE PARTS LIST</b>				
Reg. By <b>kele</b>	Appr. By <b>peto</b>	Appr. Date 2002-05-17	Page 2(14)	Class <b>053</b>	No. <b>197798</b>	Rev. <b>07</b>
Info		Product name <b>RAPID 105-106</b>				

9*		Power cable	1
10*		Casing 105	1
11	177824	Lock plate	1
12C	177923	Base unit	1
12C= 12:1-12:4, 5			
12:1	177931	Base spring	1
12:2	177907	Base	1
12:3	177899	Nut plate, base	1
12:4	177808	Foot	4
13C-1	17757601	Control unit box 200V-240V, 50 Hz	1
13C-2	17757602	Control unit box 100V-120V, 60 Hz	1
13C= 13:1-13:17,			
13:1-1	162644	Main switch 200V-240V	1
13:1-2	162677	Main switch 100V-125V	1
13:2-1	17857401	Internal wiring 1, 200V-240V	1
13:2-2	17857402	Internal wiring 1, 100V-125V	1
13:3	156828	Connection terminal	1
13:4	177451	Control unit box, left	1
13:5	154062	Screw	1
13:6	177477	Sight shield lever	1
13:7	177345	Sight shield switch arm	1
13:8	177493	Nut plate	2
13:9	177535	Impact control	1
13:10	177444	Control unit box, right	1
13:11	177519	Spring, flap	1
13:12	155481	Lock washer	1
13:13	177501	Flap	1
13:14	177485	Sight shield spring	2
13:15	177543	Knob spring	1
13:16	177295	Sight shield	1
13:17	177527	Terminal cover	1
14C-1	17910101	Control unit complete, 220V, 50 Hz	1
14C-2	17910102	Control unit complete 115V, 60 Hz	1
14C= 14:1-14:8			
14:1*		Control unit	1
14:2	169821	Socket	1
14:3	168724	Nut	1
14:4	178533	Internal wiring	1
14:5-1	17851701	Internal wiring 2, 200V-240V	1
14:5-2	17851702	Internal wiring 2, 100V-125V	1
14:6	17858203	Connecting wire, white	1
14:7	17858202	Connecting wire, green	1
14:8	17858201	Connecting wire, white	1

*When ordering always state then part numbers*

**Head office and factory: ISABERG RAPID AB, Box 115, S-330 27 Hestra, Sweden**

**Telephone 46-(0)370-33 95 00. Telefax 46-(0)370-33 95 02.**

**Internet [www.isaberg-rapid.com](http://www.isaberg-rapid.com)**

<b>Rapid</b> 		<b>SPARE PARTS LIST</b>				
Reg. By <b>kele</b>	Appr. By <b>peto</b>	Appr. Date 2002-05-17	Page 3(14)	Class <b>053</b>	No. <b>197798</b>	Rev. <b>07</b>
Info		Product name <b>RAPID 105-106</b>				

15C	177303	Trigger box unit, right	1
15C= 15:1-15:14			1
15:1*		Trigger box, right	1
15:2*		Slider rod	2
15:3*		Lock washer	6
15:4*		Trigger	2
15:5*		Lock plate	2
15:6*		Washer	2
15:7*		Trigger arm	2
15:8*		Axle	2
15:9*		Pin	2
15:10*		Trigger spring	2
15:11*		Trigger rod	2
15:12*		Plastic tube	2
15:13*		Spring, trigger rod	2
15:14*		Turn spring, trigger rod	2
16C	177311	Trigger box unit, left	1
16C=16:1, 15:2-15:14			
16:1*		Trigger box, left	1
17	178103	Frame unit	1
18	178129	Nut plate	1
19*		Casing 106	1
20	178038	Foot	4
21	178020	Spacing tube	4
22	146381	Fixing knob	1
23	128595	Washer	1
24C	16705301	Fixing set	1
24C=24-1, 26,27,36			
24:1*		Screw	1
25	14672010	Anvil	1
26*		Anvil support	1
27*		Nut	1
28	167163	Screw	2
29C**	14674612	Big table, 106 original	1
29C=29:1- 29:7,30,31,			
29:1*		Table	1
29:2	128397	Bolt	2
29:3	128579	Bar, right	1
29:4	155457	Lockwasher	2
29:5	128561	Bar, left	1
29:6	146712	Spring	2
29:7	128538	Paper gauge	2

*When ordering always state then part numbers*

**Head office and factory: ISABERG RAPID AB, Box 115, S-330 27 Hestra, Sweden**

**Telephone 46-(0)370-33 95 00. Telefax 46-(0)370-33 95 02.**

**Internet [www.isaberg-rapid.com](http://www.isaberg-rapid.com)**

<b>Rapid</b> 		<b>SPARE PARTS LIST</b>				
Reg. By <b>kele</b>	Appr. By <b>peto</b>	Appr. Date <b>2002-05-17</b>	Page <b>4(14)</b>	Class <b>053</b>	No. <b>197798</b>	Rev. <b>07</b>
Info		Product name <b>RAPID 105-106</b>				

30	128546	Clamp	1
31	162032	Screw	1
32	156273	Fixing knob	1
33C**	10880011	Foot control unit 106 original	1
33C= 33:1-33:4			
33:1**	10880302	Foot control unit 105, no cover	1
33:2	168823	Plug	1
33:3	146423	Cover	1
33:4	162420	Screw	2
34	178053	Fixed spanner, 8 mm	1
35	128504	Guide plate 66/8	1
36*		Washer	1
37	10841512	Insert stapler Rapid A2EI-105, 66/6-8, see page 8	1
38	10842312	Insert stapler Rapid A2EI-106, 66/6-8, see page 9	1

#### SPARE PARTS - EXTRA ACCESSORIES

A252-106**	10843112	Insert stapler Rapid A252-106, 66R/6 (for loops staples), see page 10	1
200C**	17824412	Narrow table 106, see page 11	1
201C**	108811	Multi base 105, see page 12	1
202C**	178004	Vice 105, see page 13	1
203C**	108829	Saddle Runner 106, see page 14	1
**	17774101	Optocable 400 mm	
**	17774102	Optocable 700 mm	



**Rapid****SPARE PARTS LIST**

Reg. By <b>kele</b>	Appr. By <b>peto</b>	Appr. Date 2002-05-17	Page 6(14)	Class <b>053</b>	No. <b>197798</b>	Rev. <b>07</b>
Info		Product name <b>RAPID 105-106</b>				

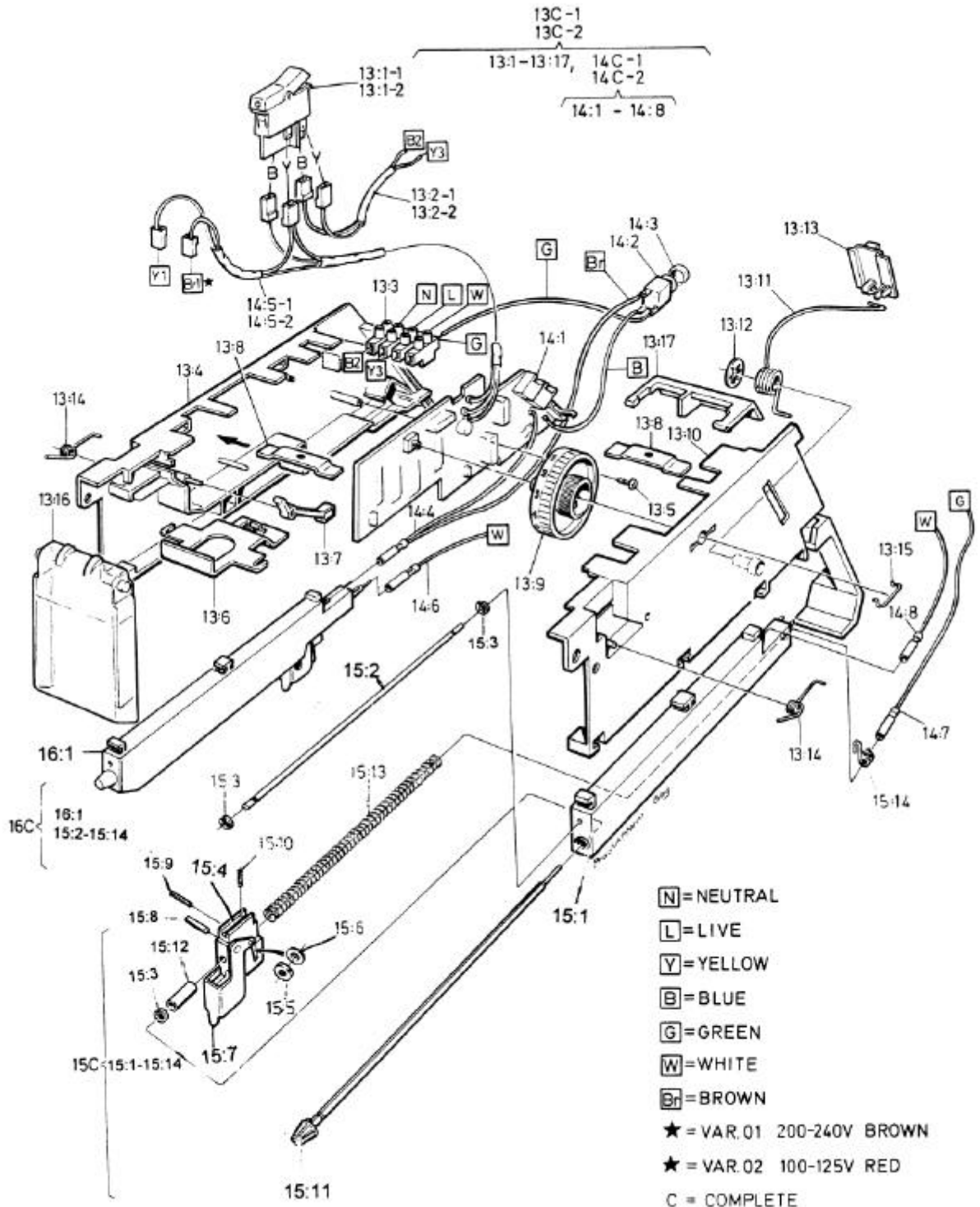

*When ordering always state then part numbers*  
**Head office and factory: ISABERG RAPID AB, Box 115, S-330 27 Hestra, Sweden**  
**Telephone 46-(0)370-33 95 00. Telefax 46-(0)370-33 95 02.**  
**Internet [www.isaberg-rapid.com](http://www.isaberg-rapid.com)**

<b>Rapid</b> 		<b>SPARE PARTS LIST</b>				
Reg. By <b>kele</b>	Appr. By <b>peto</b>	Appr. Date <b>2002-05-17</b>	Page <b>7(14)</b>	Class <b>053</b>	No. <b>197798</b>	Rev. <b>07</b>
Info		Product name <b>RAPID 105-106</b>				

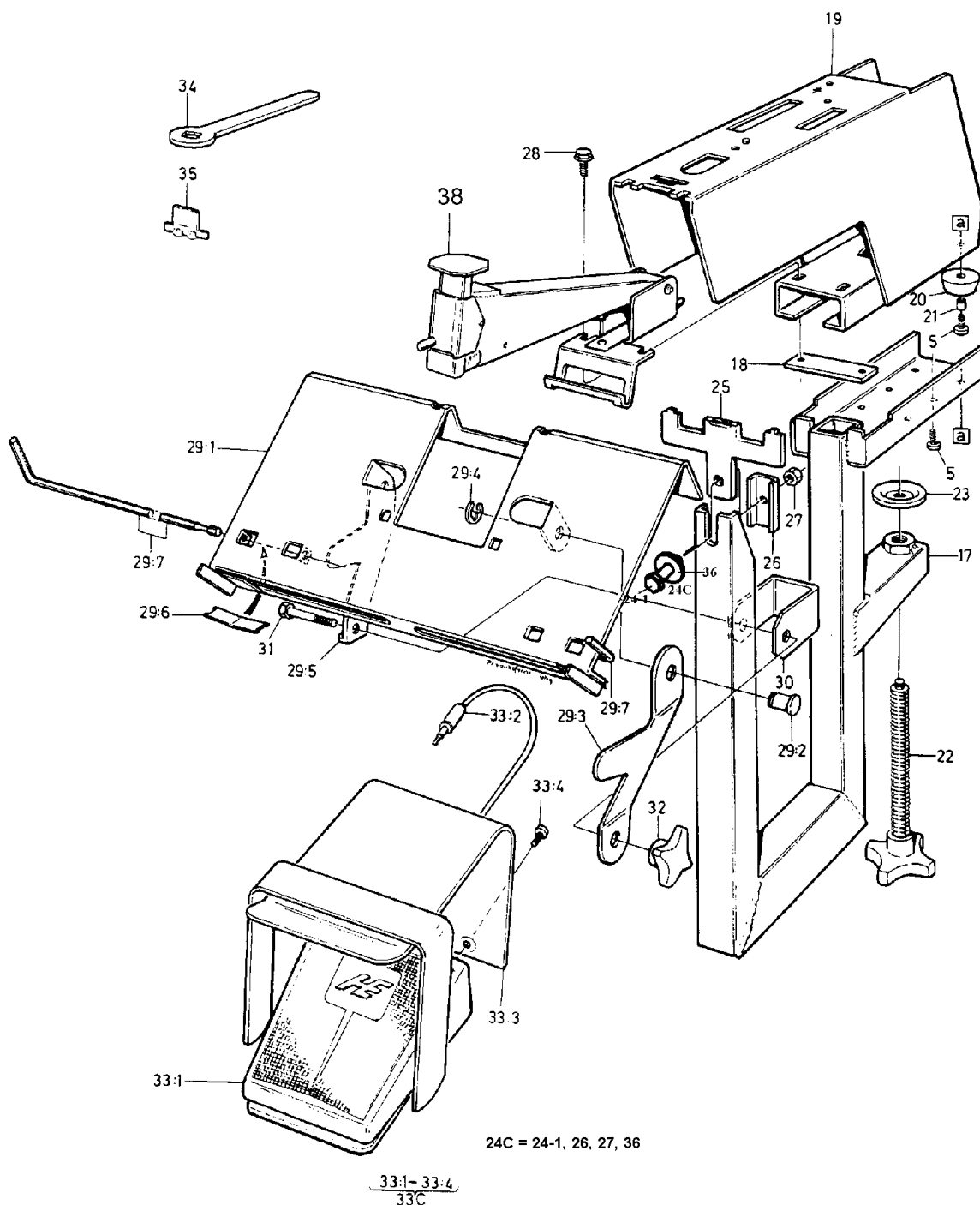

When ordering always state then part numbers  
 Head office and factory: ISABERG RAPID AB, Box 115, S-330 27 Hestra, Sweden  
 Telephone 46-(0)370-33 95 00. Telefax 46-(0)370-33 95 02.  
 Internet [www.isaberg-rapid.com](http://www.isaberg-rapid.com)

<b>Rapid</b> 		<b>SPARE PARTS LIST</b>				
Reg. By <b>kele</b>	Appr. By peto	Appr. Date 2002-05-17	Page 8(14)	Class <b>053</b>	No. <b>197798</b>	Rev. <b>07</b>
Info		Product name <b>RAPID 105-106</b>				

**# 37 Insert Stapler Rapid A2EI-105 66/6-8 Rapid**  
Part No 10841512

Pos No	Part No	Name	Qty
30	12105301	Piston incl driver	1
31	120907	Piston spring	1
32	155648	Pin	1
33	120964	Plastic knob	1
43	120923	Pin	1
46	16441802	Front	1
55	148932	Magazine, compl 66-staples	1

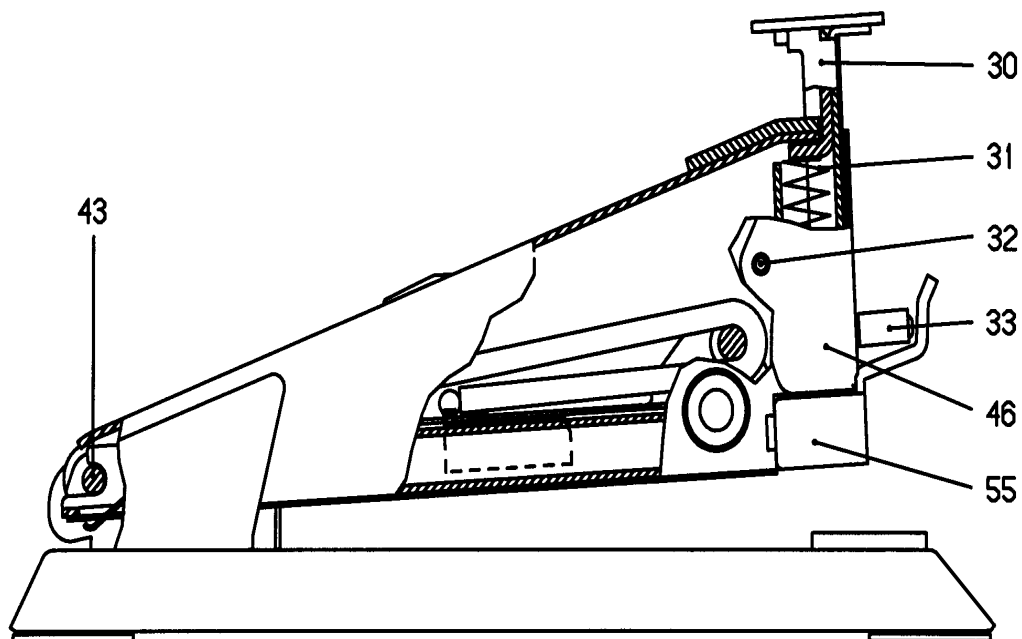

*When ordering always state then part numbers*  
**Head office and factory: ISABERG RAPID AB, Box 115, S-330 27 Hestra, Sweden**  
**Telephone 46-(0)370-33 95 00. Telefax 46-(0)370-33 95 02.**  
**Internet [www.isaberg-rapid.com](http://www.isaberg-rapid.com)**



<b>Rapid</b> 		<b>SPARE PARTS LIST</b>				
Reg. By <b>kele</b>	Appr. By <b>peto</b>	Appr. Date 2002-05-17	Page 9(14)	Class <b>053</b>	No. <b>197798</b>	Rev. <b>07</b>
Info		Product name <b>RAPID 105-106</b>				

**# 38 Insert stapler Rapid A2EI-106 66/6-8**

Part No 10842312

Pos No	Part No	Name	Qty
30	12105301	Piston incl driver	1
31	120907	Piston spring	1
32	155648	Pin	1
33	120964	Plastic knob	1
43	120923	Pin	1
46	16441803	Front	1
55	148932	Magazine, compl 66-staples	1

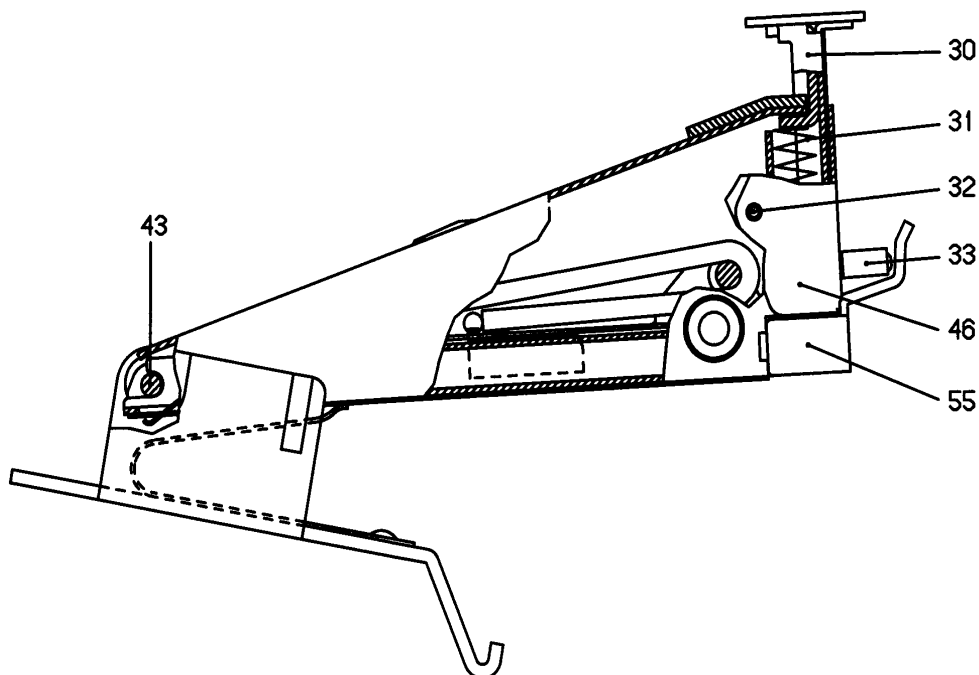

# Pos No - see page 4 or exploded drawing

When ordering always state then part numbers  
 Head office and factory: ISABERG RAPID AB, Box 115, S-330 27 Hestra, Sweden  
 Telephone 46-(0)370-33 95 00. Telefax 46-(0)370-33 95 02.  
 Internet [www.isaberg-rapid.com](http://www.isaberg-rapid.com)

<b>Rapid</b> 		<b>SPARE PARTS LIST</b>				
Reg. By <b>kele</b>	Appr. By peto	Appr. Date 2002-05-17	Page 10 (14)	Class <b>053</b>	No. <b>197798</b>	Rev. <b>07</b>
Info		Product name <b>RAPID 105-106</b>				

**A252-106 66R/6 Insert stapler Rapid (extra accessory)**

Pos No	Part No	Name	Qty
1	120964	Plastic knob	1
2	16434301	Piston incl driver	1
3	164459	Piston spring	1
4	155648	Pin	1
17	120923	Pin	1
18	16441805	Front	1
21	16448302	Magazine, compl 66R/6-staples	1

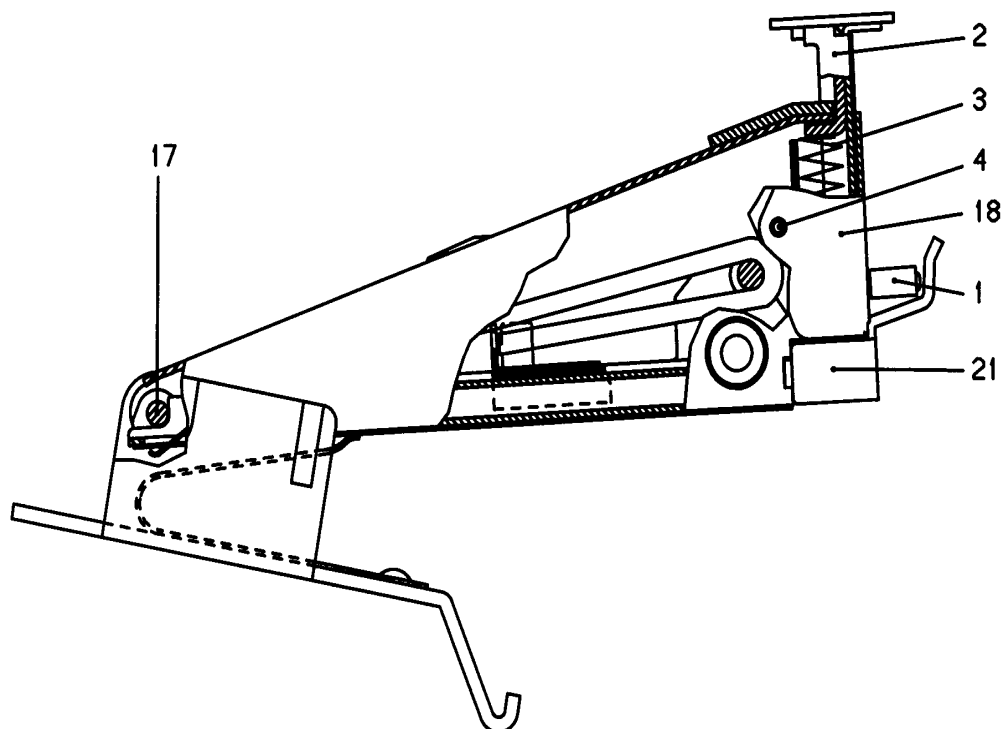

*When ordering always state then part numbers*  
**Head office and factory: ISABERG RAPID AB, Box 115, S-330 27 Hestra, Sweden**  
**Telephone 46-(0)370-33 95 00. Telefax 46-(0)370-33 95 02.**  
**Internet [www.isaberg-rapid.com](http://www.isaberg-rapid.com)**

<b>Rapid</b> 		<b>SPARE PARTS LIST</b>				
Reg. By <b>kele</b>	Appr. By peto	Appr. Date 2002-05-17	Page 11 (14)	Class <b>053</b>	No. <b>197798</b>	Rev. <b>07</b>
Info		Product name <b>RAPID 105-106</b>				

**200C\*\* Narrow table 106**

Pos No	Part No	Name	Qty
200:1	178210	Table 106	1
200:2	178228	Nut plate	1
200:3	162313	Knob screw	1
200:4	178194	Bar, right	1
200:5	155457	Lock washer	2
200:6	178186	Bar, left	1
200:7	178236	Paper Gauge	2
200:8	178145	Anvil 106	1
30	128546	Clamp	1
31	162032	Screw	1
32	156273	Fixing knob	1

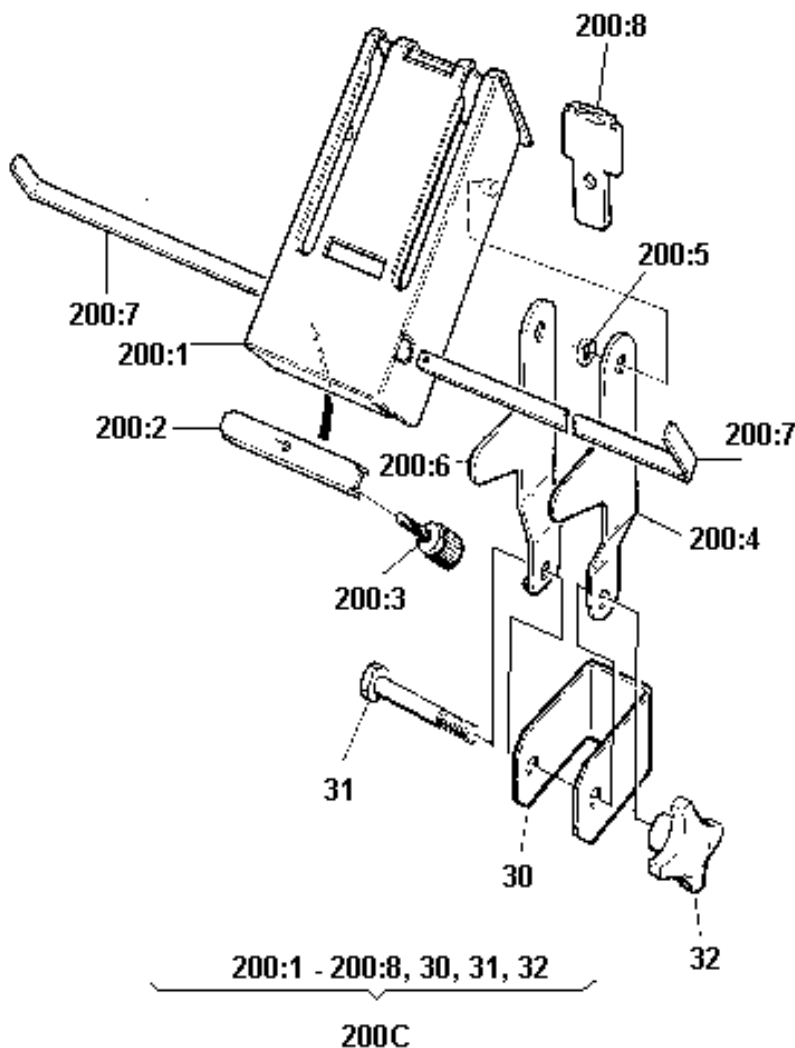

*When ordering always state then part numbers*  
**Head office and factory: ISABERG RAPID AB, Box 115, S-330 27 Hestra, Sweden**  
**Telephone 46-(0)370-33 95 00. Telefax 46-(0)370-33 95 02.**  
**Internet [www.isaberg\\_rapid.com](http://www.isaberg_rapid.com)**

<b>Rapid</b> 		<b>SPARE PARTS LIST</b>				
Reg. By <b>kele</b>	Appr. By peto	Appr. Date 2002-05-17	Page 12 (14)	Class <b>053</b>	No. <b>197798</b>	Rev. <b>07</b>
Info		Product name <b>RAPID 105-106</b>				

### 201C\*\* Multi base 105

Pos	Part No	Name	Qty
201:1	177915	Spreader bar, short	1
201:2	177980	Spreader bar, long	1
201:3	177790	Device for fixture	2
201:4*		Multi base	1
201:5	177832	Foot, device for fixture	4
201:6	178319	Foot, table	4
201:7	154211	Screw	4
201:8	155218	Washer	4
201:9	15453402	Screw	4

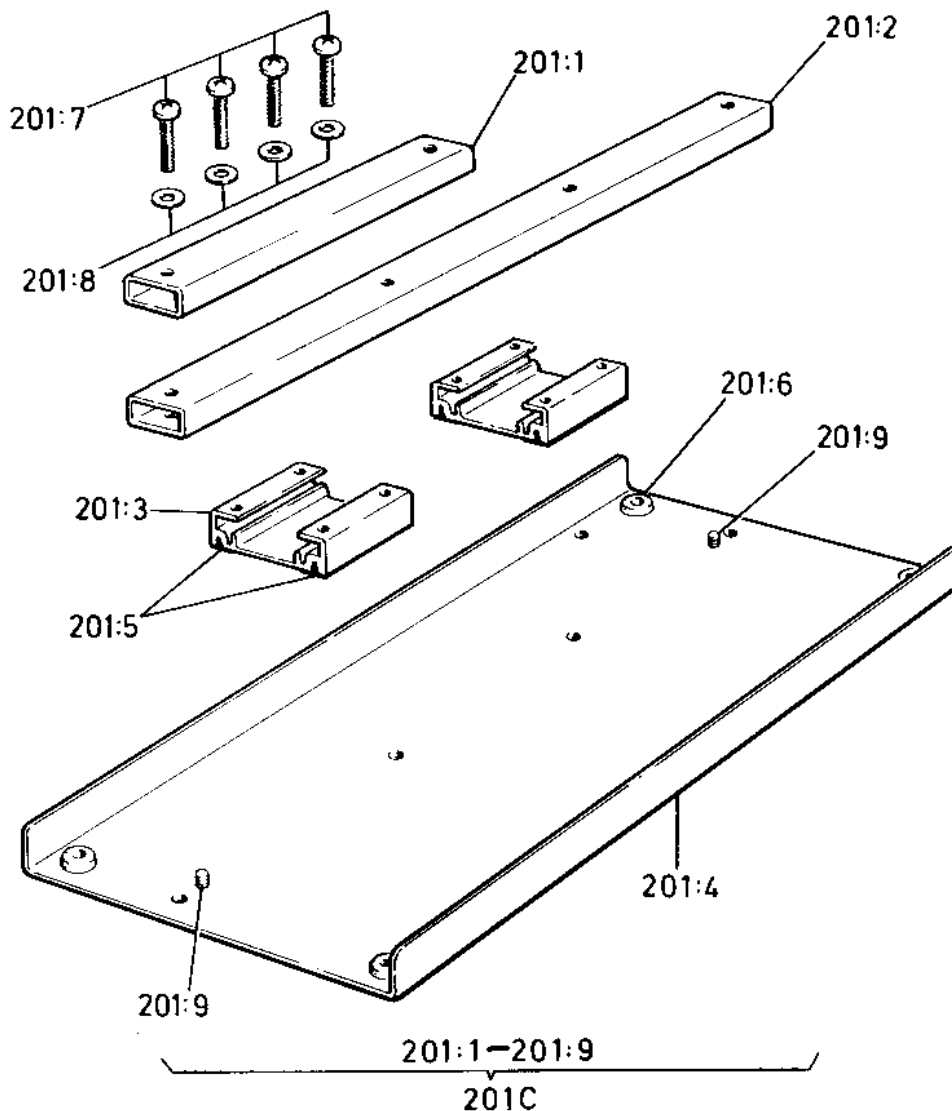

When ordering always state then part numbers  
**Head office and factory: ISABERG RAPID AB, Box 115, S-330 27 Hestra, Sweden**  
**Telephone 46-(0)370-33 95 00. Telefax 46-(0)370-33 95 02.**  
 Internet [www.isaberg\\_rapid.com](http://www.isaberg_rapid.com)

<b>Rapid</b> 		<b>SPARE PARTS LIST</b>				
Reg. By <b>kele</b>	Appr. By peto	Appr. Date 2002-05-17	Page 13(14)	Class <b>053</b>	No. <b>197798</b>	Rev. <b>07</b>
Info		Product name <b>RAPID 105-106</b>				

**202C\*\* Vice 105**

Pos	Part No	Name	Qty
202:1	178301	Foot, vice	1
202:2*		Vice	1
201:3	177790	Device for fixture	1
201:5	177832	Foot, device for fixture	2
22	146381	Fixing knob	1
23	128595	Washer	1

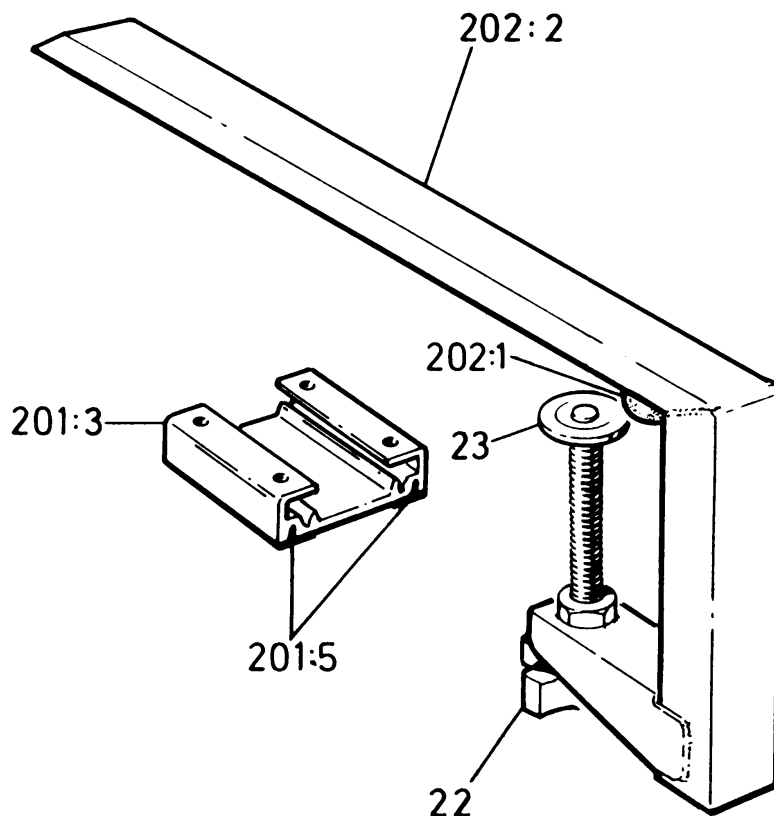

202:1-202:2, 201:3, 201:5, 22, 23,  
202C

<b>Rapid</b> 		<b>SPARE PARTS LIST</b>				
Reg. By <b>kele</b>	Appr. By peto	Appr. Date 2002-05-17	Page 14 (14)	Class <b>053</b>	No. <b>197798</b>	Rev. <b>07</b>
Info		Product name <b>RAPID 105-106</b>				

<b>203C** Runner 106</b>			
<b>Pos No</b>	<b>Part No</b>	<b>Name</b>	<b>Qty</b>
200:8	178145	Anvil 106	1
203:1	178764	Runner plate	2
203:2	167197	Screw	2
203:3	178871	Holder incl screw 203:2	2

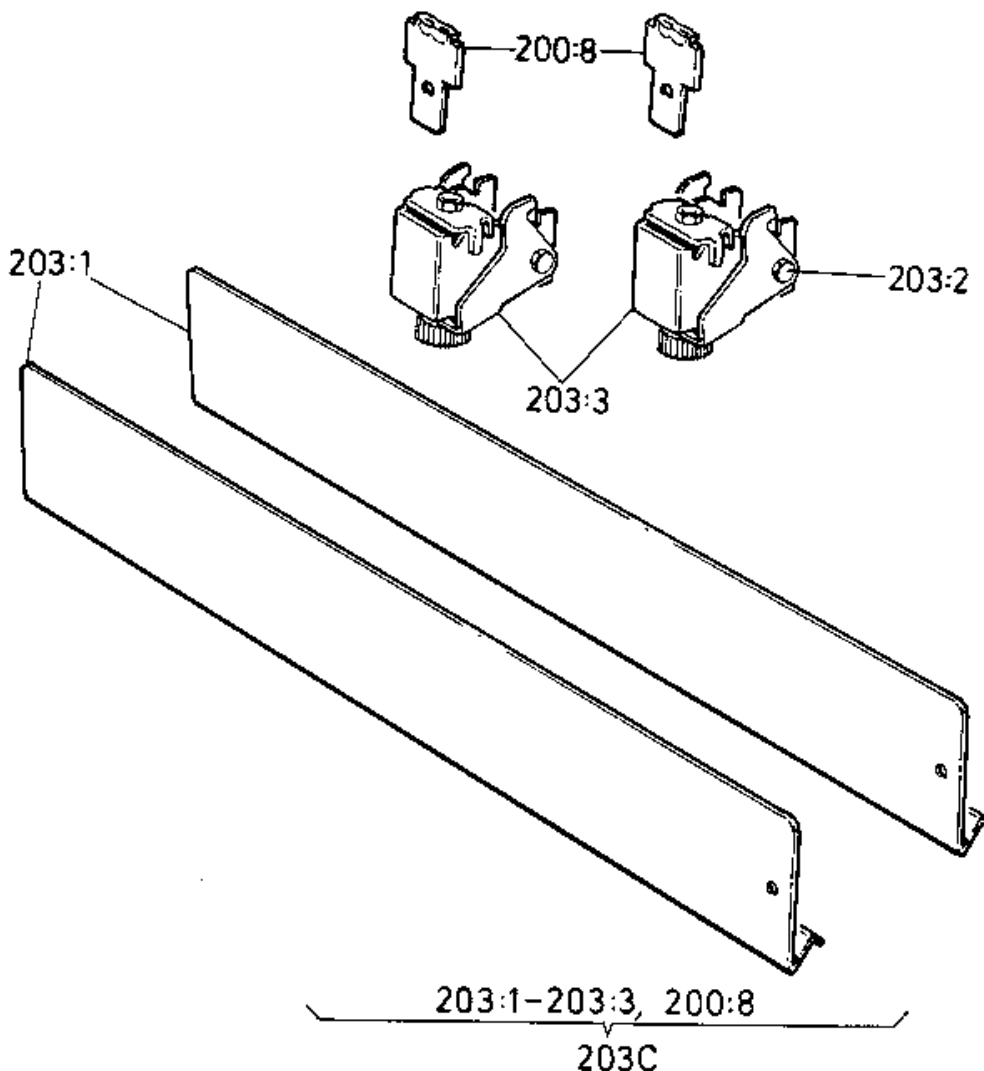

*When ordering always state then part numbers*  
**Head office and factory: ISABERG RAPID AB, Box 115, S-330 27 Hestra, Sweden**  
**Telephone 46-(0)370-33 95 00. Telefax 46-(0)370-33 95 02.**  
**Internet [www.isaberg-rapid.com](http://www.isaberg-rapid.com)**