

438S2

ACCESSORIES AVAILABLE / ACCESORIOS DISPONIBLES / ACCESSOIRES DISPONIBLES

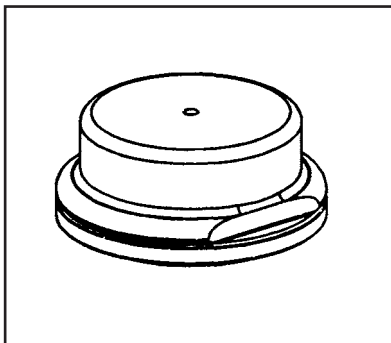

96

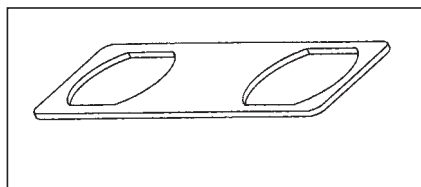

95

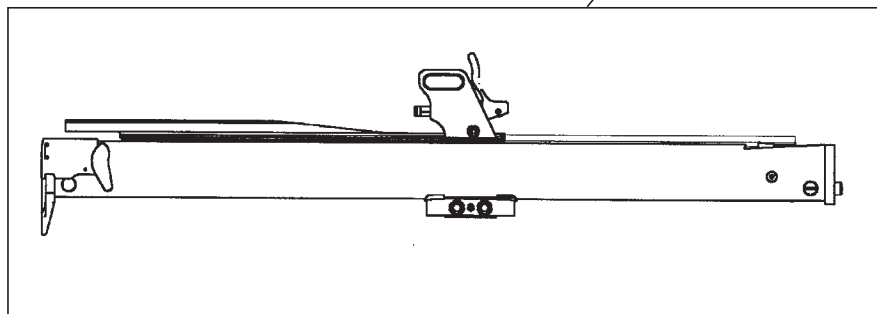

94

BOSTITCH®

438S2

**PNEUMATIC STAPLER
ENGRAPADORA NEUMÁTICA
AGRAFEUSE PNEUMATIQUE**



TOOL PARTS ILLUSTRATION ILUSTRACIÓN DE LAS PIEZAS DE LA HERRAMIENTA ILLUSTRATION DES PIÈCES D'OUTILLAGE

⚠ WARNING:

⚠ ADVERTENCIA:

⚠ ATTENTION:

BEFORE PERFORMING REPAIRS ON THIS TOOL, ALL OPERATORS SHOULD STUDY THIS ILLUSTRATION, AS WELL AS THE PARTS LIST AND OPERATION AND MAINTENANCE MANUAL. OPERATORS SHOULD UNDERSTAND AND FOLLOW ALL SAFETY WARNINGS AND INSTRUCTIONS. KEEP THIS ILLUSTRATION WITH THE TOOL FOR FUTURE REFERENCE. IF YOU HAVE ANY QUESTIONS, CONTACT YOUR BOSTITCH REPRESENTATIVE OR DISTRIBUTOR.

ANTES DE LLEVAR A CABO CUALQUIER REPARACIÓN EN LA HERRAMIENTA, TODOS LOS OPERARIOS DEBERÁN ESTUDIAR ESTA ILUSTRACIÓN, ASÍ COMO LA LISTA DE PIEZAS Y EL MANUAL DE OPERACIÓN Y MANTENIMIENTO. LOS OPERARIOS DEBERÁN ENTENDER Y SEGUIR TODAS LAS ADVERTENCIAS E INSTRUCCIONES DE SEGURIDAD. CONSERVE ESTA ILUSTRACIÓN CON LA HERRAMIENTA PARA PODER CONSULTARLA EN LO FUTURO. SI TUVIERA ALGUNA PREGUNTA, PONGASE EN CONTACTO CON SU REPRESENTANTE O DISTRIBUIDOR DE BOSTITCH.

AVANT DE PROCÉDER À LA RÉPARATION DE CET OUTIL, LES OPÉRATEURS DOIVENT ÉTUDIER LA PRÉSENTE ILLUSTRATION AINSI QUE LA LISTE DE PIÈCES ET LE MANUEL D'INSTRUCTIONS ET D'ENTRETIEN ; ILS DOIVENT ÉGALEMENT COMPRENDRE ET OBSERVER LES CONSIGNES DE SÉCURITÉ ET LES INSTRUCTIONS. CONSERVER CETTE ILLUSTRATION AVEC L'OUTIL POUR RÉFÉRENCE FUTURE. SI VOUS AVEZ DES QUESTIONS, COMMUNIQUEZ AVEC VOTRE REPRÉSENTANT OU VOTRE DISTRIBUTEUR DE BOSTITCH.

BOSTITCH®
STANLEY FASTENING SYSTEMS

438S2

PNEUMATIC STAPLER
ENGRAPADORA NEUMÁTICA
AGRAFEUSE PNEUMATIQUE

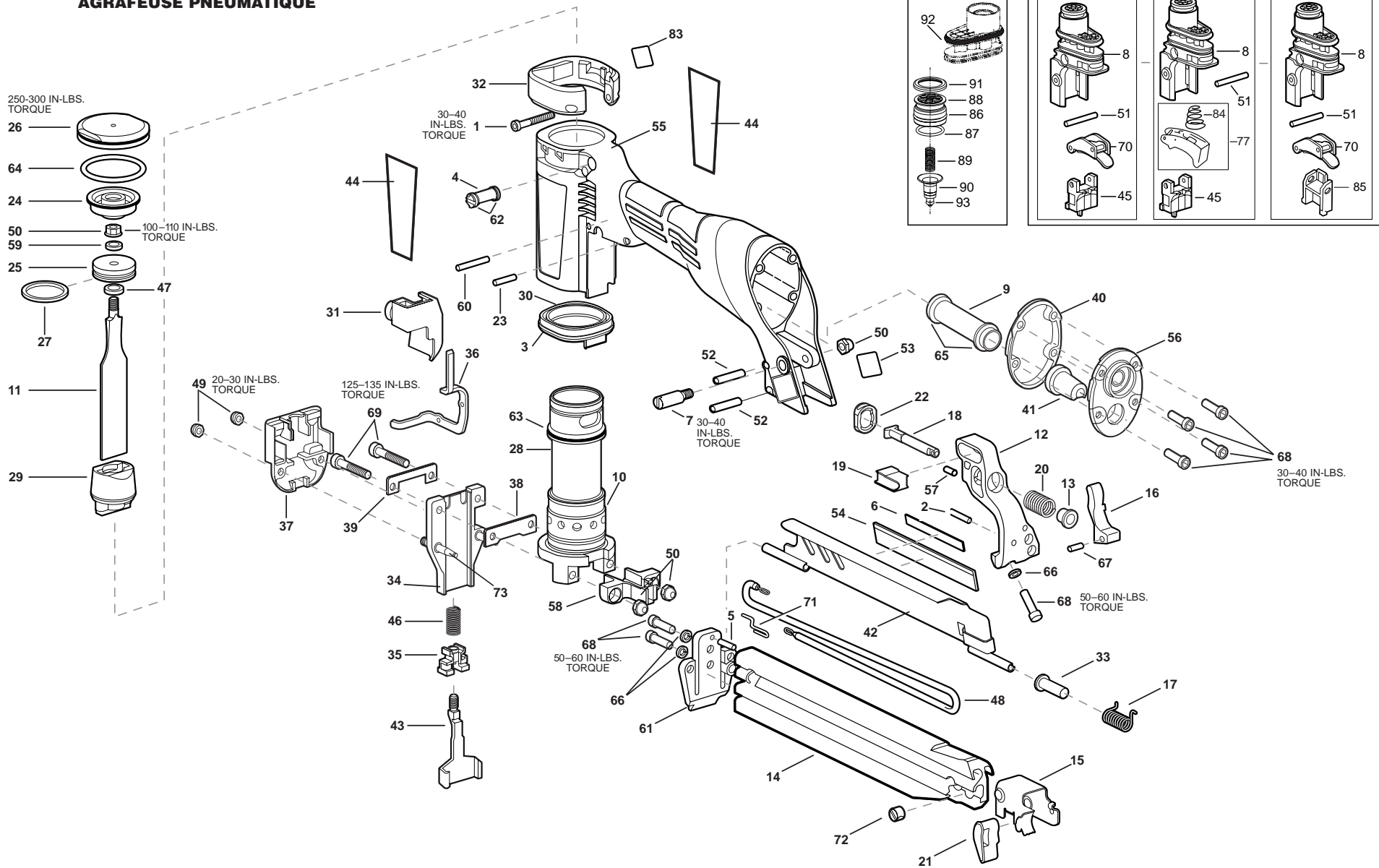

SEE REVERSE SIDE FOR ACCESSORIES
 (NOT INCLUDED)

438S2

PRINT

[< Show Schematic](#)[< Parts Price List](#)

ITEM	PART #	DESCRIPTION	ITEM	PART #	DESCRIPTION
1	100258	SCREW,SHCS,M4X0.7X35	54	158612	LABEL,WARNING
2	100263	PIN,SPIROL,M4X14MM	55	121168	FRAME (L/P)
3	100279	O-RING,1.612X.103	56	106292	CAP,END L/P
4	101525	VALVE,ENERGY CONTROL	57	106334	PIN,SPIRAL 4X10MM
5	102044	PIN,SPIROL 3MMX16MM	58	106474	TOP GUIDE
6	102167	LABEL,MAGAZINE CAPACITY	59	106691	WASHER,SPECIAL M6
7	102168	SCREW,SPECIAL (MAGAZINE)	60	106871	PIN,SPRING 4X32MM
8	TVA9	KIT,STANDARD MODULE	61	107072	TIP CORE (1.5IN)
9	103208	TUBE,EXHAUST	62	107129	O-RING,.268X.075
10	103211	SEAL,CHECK	63	850607	O-RING,1.484X.139
11	103214	DRIVER,(1IN)	64	850628	O-RING,1.734X.139
12	103217	BRACKET,MAGAZINE	65	851554	O-RING,.703X.103
13	103218	BUSHING,TOGGLE PIN	66	MLW5	WASHER,HSLW M5
14	103219	ASSEMBLY,MAGAZINE 1.5IN	67	MPG030012	PIN,SPRING,M3X12MM
15	103222	PUSHER (1IN)	68	MSC5080-20	SCREW,SOC HD. CAP M5 X 20
16	103447	TOGGLE,MAGAZINE	69	MSC6100-35	SCREW,SHCS,M6X1.00X35
17	103549	SPRING,COVER	70	CNTK2	KIT,CONTACT TRIP CONVERSION
18	103558	LATCH,MAGAZINE	71	T50078	ANCHOR,PUSHER SPRING
19	103601	SLEEVE,BRACKET	72	T60024	PIN,SPECIAL(MAG NUT)
20	103770	SPRING,COMPRESSION	73	104069	PIN,NOSE
21	103791	HANDLE,PUSHER	77	SEQ5	KIT,SEQUENTIAL
22	103795	DISC,LATCH STOP	83	110009	LABEL,POWER VALVE
23	103858	PIN,SPRING,4X20MM	84	100387	SPRING,COMPRESSION
24	103993	BUMPER,TOP L/P	85	106173	STOP,TRIGGER
25	103994	PISTON	86	102164	O-RING,.728X.059
26	103995	CAP,SLEEVE L/P	87	102163	O-RING,.591X.059
27	166045	RING,PISTON	88	101541	HEAD VALVE
28	103997	SLEEVE,CYLINDER-L/P	89	101540	SPRING,COMPRESSION
29	103998	BUMPER,LOWER L/P (1")	90	101533	SEAL,EXHAUST
30	103999	BULKHEAD,SLEEVE - L/P	91	101532	SEAL,HEAD VALVE
31	104027	COVER,TRIP L/P	92	102197	O-RING,1.174 X .103
32	104064	PROTECTOR,FRONT FRAME L/P	93	105996	O-RING,.087X.059
33	104067	BUSHING,MAGAZINE COVER	94	108212	ASSY,400/500 SERIES S2 LM
34	160198	NOSE,S2	95	106427	WRENCH,SLEEVE CAP
35	104339	ADJUSTER,TRIP	96	112604	CAP,WEIGHT-L/P
36	104623	ARM,UPPER CONTACT			
37	104931	CASTING,NOSE COVER			
38	104974	WEARPLATE (1IN)			
39	104975	PLATE,NOSE			
40	105057	GASKET,END CAP L/P			
41	105070	EXHAUST DEFLECTOR			
42	105073	COVER,MAGAZINE			
43	105163	ARM,CONTACT			
44	105797	LABEL			
45	105932	ARM GUIDE ASSEMBLY			
46	105934	SPRING,COMPRESSION			
47	105959	WASHER,PISTON			
48	106051	SPRING,EXTENSION			
49	MHE5080-100	NUT,NYLON M5X.80			
50	MHE6100-100	NUT,ESN M6X1			
51	106058	PIN,SPRING,M3X32			
52	106059	PIN,ROLL,M4X30MM			
53	106097	LABEL,PATENT			