

ENGLISH	3
SVENSKA	12
DEUTSCH	22
FRANÇAIS	32

OPERATING INSTRUCTIONS

Translation of original manual

BRUKSANVISNING

Originalmanual

BETRIEBSANLEITUNG

Übersetzung der Originalbetriebsanleitung

MODE D'EMPLOI

Traduction du mode d'emploi original

JK20T779L

From serie no1402486

Från serienummer 1402486

Ab Serie-Nr. 1402486

A partir du no de série 1402486

Pneumatic stapling pliers

Pneumatisk häftång

Druckluft-Heftzange

Agrafeuse pince pneumatique



Before using the tool, read the operating instructions carefully.

Läs igenom bruksanvisningen noga innan du använder klammerverkyget.

Vor dem Gebrauch des Gerätes die Betriebsanleitung aufmerksam lesen.

Avant l'utilisation de l'appareil, consultez soigneusement le mode d'emploi.



TABLE OF CONTENTS

	Page
1 Technical data	2
2 General information	3
2.1 Information on environmental protection	3
3 Safety instructions	4
4 Description	5
4.1 Design	5
4.2 Function	5
5 Initial operation	6
5.1 Installation	6
5.2 Compressed-air connection / Lubrication	6
6 Operating instructions	7
6.1 Loading the stapler	7
6.2 Operating the bottom stapler	7
7 Preventive and corrective maintenance	8
7.1 Cleaning the stapler	8
7.2 Removing jammed staples	8
7.3 Replace feed spring or pusher	9
7.4 Replace driver blade	9
7.5 Control the clinch	10
7.6 Adjust the clinch	10
8 Trouble shooting	11
9 Spare parts kit	42
10 Parts list with recommended wear parts	43
Exploded drawing	45

SE JOSEF KIHLBERG AB
 Industrigatan 37B
 SE-544 50 HJO
 Telephone: +46 503 328 00
 Fax: +46 503 328 01
 E-mail: reception@kihlberg.se
 Internet: www.kihlberg.com

1 TECHNICAL DATA

Weight	2,3 kg (5,1 lbs)
Dimensions	Length 375 mm (14,8") Width 68 mm (2,7") Height 250 mm (9,8")
Magazine capacity	168 staples
Staple leg length	8 - 16 mm (5/16" - 5/8")
Nose length	14 mm (0,6 in.)
Throat depth	140 mm (5,5 in.)
Recommended working air pressure	5 - 6 bar (75-85 psi)
Max. air pressure	7 bar (100 psi)
Air consumption per driving operation at 6 bar operating pressure	0.4 litres
Noise characteristic levels according to: EN 12549	
A-weighted single-event emission sound pressure level at work station	89 dB
A-weighted sound energy level	96 dB
Vibration level:	Vibration below the limit of declaration according to EN 792- 13 measured according to ISO 8662-11.

FASTENERS

Staple JK779-08 (5/16")	Art.No 400368
Staple JK779-10 (3/8")	Art.No 400370
Staple JK779-12 (1/2")	Art.No 400372
Staple JK779-14 (9/16")	Art.No 400373
Staple JK779-16 (5/8")	Art.No 400375

DECLARATION OF CONFORMITY

We take sole responsibility for declaring that the bottom stapler JK20T779L, to which this declaration refers, is in full compliance with the current requirements of the guidelines laid down by the council on 17th May 2006 (2006/42/EG) "Machine Guidelines".
 Complies with norms: ISO 12100:2010

SE-544 50 HJO, 11.06.2014
 Production Manager:

 Anders Pettersson
 Agent for the publication of technical documentation:
 Josef Kihlberg AB, Industrigatan 37B SE-544 50 HJO



2

GENERAL INFORMATION



CAUTION!

Used where there is danger to life and health.



WARNING!

Used for danger which can cause material damage.



NOTE!

Used for general information and information which if not followed can cause faults in the operating sequence.

These operating instructions are intended to simplify familiarisation with the pliers and the possibilities of application for the intended purpose. The operating instructions contain important information concerning the safe, proper and efficient use of the pliers. Observation of the information will help to avoid danger, reduce repairs and stoppages and increase the reliability and service life of the pliers.

The operating instructions must always be available at the place of operation of the pliers. They must be read and observed by all persons concerned with work on the pliers. This work specifically includes operation, refilling of operating material, fault elimination and maintenance.

In addition to the operating instructions and the regulations for accident prevention effective in the country of use and place of application, the recognised technical regulations for safety and proper working must also be observed.

2.1 INFORMATION ON ENVIRONMENTAL PROTECTION

This stapler is manufactured without any physical or chemical substances which could be dangerous to health. For disposal of all the parts, the governmental instructions must be observed.

3

SAFETY INSTRUCTIONS



Inform yourself!
Read the operating instructions carefully.



Original JOSEF KIHHLBERG staples must be used exclusively!



Protect yourself!
When operating the stapler, wear eye, ear protection.



Original JOSEF KIHHLBERG spare parts must be used exclusively!
Not using original spare parts will dissolve the warranty and the liability.



Warning: Danger of crushing!
Do not put your fingers underneath the nozzle.

Use for the intended purpose

The stapler is intended for flat stapling and transport packaging of soft material to each other as card board, solid paper and fabric.



Warning: Hazard!
Lay the compressed air hose so that there is no risk of tripping over it.

This stapler was designed and manufactured for safe handling during the stapling operation.



Do not exceed the air pressure!
Do not exceed the recommended air pressure.

Possible misuse

Do not fire any staples without any material between the anvil and the nozzle. Only use the stapler on material as recommended.

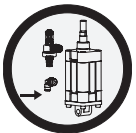

Use safety coupling!
For connecting the air hose to the stapler, use only a safety coupling.

Servicing

The following maintenance work must be carried out at regular intervals, varying with working conditions and workload:

- daily check of compressed air pressure (5–6 bar).
- clean the stapler regularly.
- check the condition of the stapler at regular intervals for defects or worn parts. Never use a stapler that has defective or worn parts (for servicing task refer also to chapter 7.1 and 7.2).



Do not use a bottled air or gas source!
Do not operate this stapler by using a bottled air or gas source.



Never leave a loaded tool unattended!
Always disconnect the tool from air supply when not in use.

4

DESCRIPTION

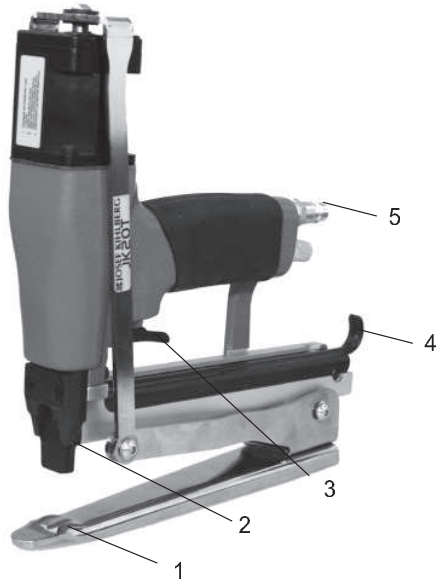

Fig. 1

4.1 DESIGN

- 1 Anvil
- 2 Door
- 3 Trigger
- 4 Magazine lid
- 5 Nipple

4.2 FUNCTION

The pliers JK20T has only single shot firing without safety yoke.

1. First place the tool around the work piece,
2. then pull the trigger (Fig.1/3).

To avoid damage to the driver blade in the tool, never fire it without any work piece.



Warning: before stapling ensure that your hand or any other part of your body is not underneath the nozzle.

5

INITIAL OPERATION

5.1 INSTALLATION

The stapler is delivered without nipple assembled. Assemble the nipple as following:

1. Take the stapler out of the box. Check that the nipple is the correct brand and fits your air system. Put sealing compound at the threadle. (Fig. 2/1).
2. Assemble the nipple. Tightening torque 7.5 Nm.



Lay the compressed air hose so there is no risk of tripping over it.



Fig. 2

5.2 AIR CONNECTION / LUBRICATION



Properly prepared compressed air is essential for trouble free operation of the stapler. This can only be ensured by a reliably functioning maintenance unit, consisting of water separator, pressure reducing valve with pressure gauge. The internal diameter of the pipe should be at least 10 mm ($\frac{3}{8}$ ").



Never exceed the maximum permitted air pressure of 7 bar (110 psi). The maximum supply pressure is 8 bar (110 psi).

A low air pressure will give low maintenance costs!

The stapler and the hose must have a coupling which automatically bleeds all air pressure from the stapler when it is disconnected.

The stapler needs a small amount of lubricating oil in the nipple each day or approx. 10 drops once a week to ensure safe functioning and endurance. For high frequency stapling we recommend oil mist lubricator. Please contact our agent for advice.

733007 Lubrication oil 0.2 dl. (Fig.3/1)

Sliding parts are greased, with Dow Corning grease MS 4 Silicon Compound, at the factory. We recommend use this grease on moving parts if they have been cleaned or replaced.

184943 Tube of MS 4. (Fig. 3/2)



733007



184943

Fig. 3

6

OPERATING INSTRUCTIONS

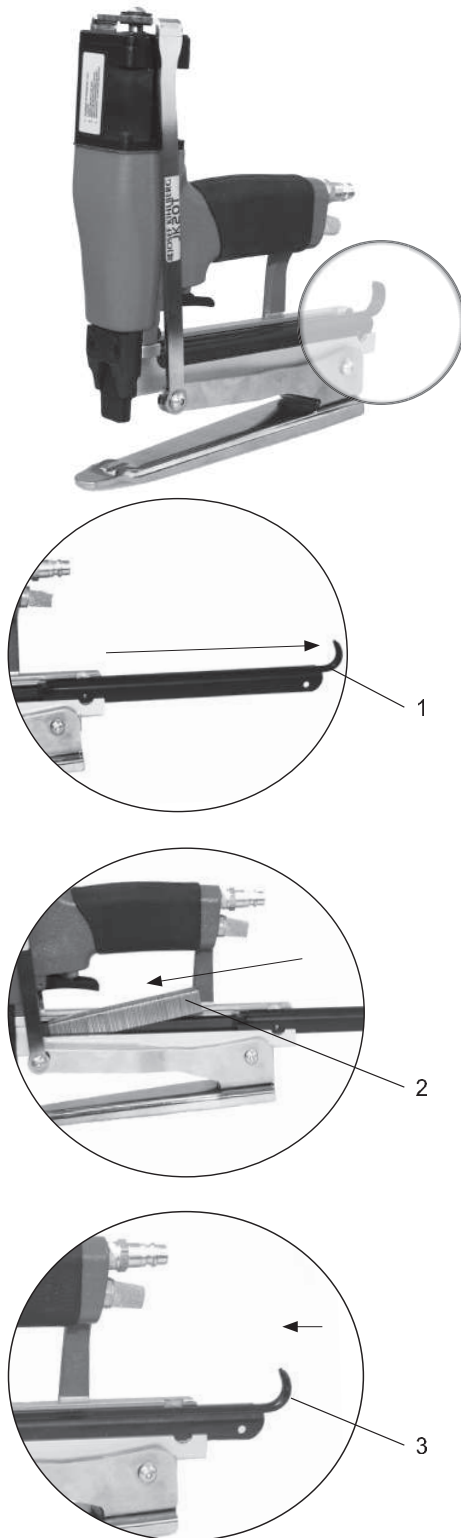

Fig. 4

6.1 LOADING THE MAGAZINE



Be sure that the tool is not pointing at yourself or anyone else when connecting it to the compressed air line.

- Connect the tool to the compressed air line before loading staples. The max. allowed air pressure is 7 bar.
- **Always use Josef Kihlberg original staples JK779 with leg length 08 (5/16") to 16 mm (5/8").**
The correct type of staple is marked on the right side of the magazine. Ensure you use the right length of staples for your application.

1. Pull the magazine lid all the way out (Fig. 4/1)
2. Place the staple strip (4/2) into the staple rail from the left hand side.
3. Place the staple strip into the magazine and push the lid (4/3) forward again until it clicks in.

6.2 OPERATING THE STAPLER

Adjust the air pressure to the lowest one that will drive the staples to the desired depth. Start at approx. 5.0 bar (72 psi) and raise this by 0.5 bar (7 psi) increments until the correct operating pressure for the job in hand is found. Never exceed 7 bar (100 psi).

A low air pressure will give low maintenance costs!



Always place yourself in a firmly balanced position when using or handling the tool. Do not drive staples at too steep an angle or too close to the edge of the work: the fastener might fly free and hurt someone.

- Place the tool firmly on the work surface. Never drive staples in extremely hard or brittle material. Do not drive staples at too steep an angle or too close to the edge of the work: the staples might fly free and hurt someone.



Warning: before stapling, ensure that your hand or any other part of your body is not underneath/between the nozzle and anvil.

- Pull the trigger as described in chapter 4,2
- Move the tools sideway until you have finished and then release the trigger.
- **Control the clinch, refer to chapter 7.5.**

7

PREVENTIVE AND CORRECTIVE MAINTENANCE



Before all maintenance tasks on the stapler always first disconnect it from the air supply.

7.1 CLEANING THE STAPLER

This stapler does not require special servicing. It only needs regular cleaning with a non-aggressive (non-corrosive) cleaner agent. Do not remove any parts for cleaning purposes!



Check the proper functioning of all safety devices daily. Make especially sure that:

- the trigger works smoothly, the door stays in place and the magazine lid does not open itself.
- all screws and nuts are securely tightened.
- the stapler is regularly lubricated (refer to chapter 5.2).

7.2 REMOVING JAMMED STAPLES

To remove a staple which has become jammed:

- Pry the door open with a screw driver (Fig. 5/1) . There are three notches in the door to simplify the disassembling.
- Remove the door.
- Check the canal for defective staples.
- Insert the door into the rear nozzle plate and push until it clicks shut.



The three notches at the door must be assembled to the front.

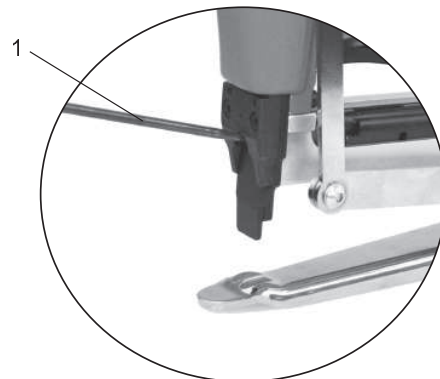

Fig. 5

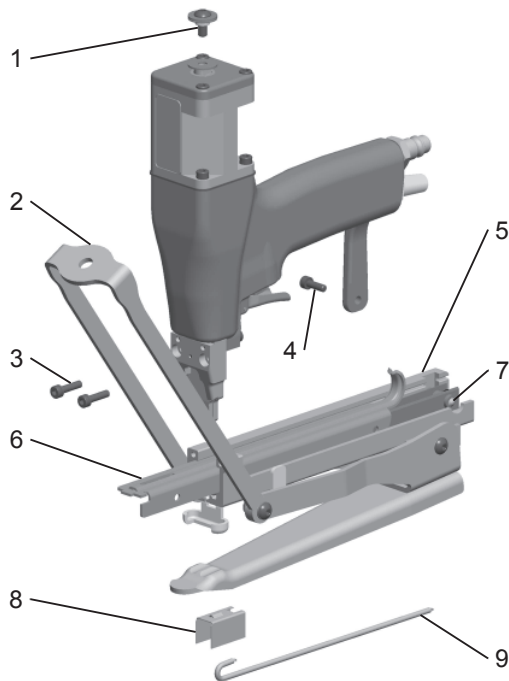

Fig. 6

7.3 REPLACE FEED SPRING

- Disconnect tool from air supply.
- Disassemble the screw (Fig. 6/1) holding the power arm (6/2) turn it underneath the magazine.
- Remove the rear screw (6/4) and the two front screws (6/3) and remove the magazine (6/5).
- Remove the magazine lid towards the front.
- Remove the pusher and it's spring.
- Mount the pusher spring under the front roller.
- First mount the pusher; tension the pusher spring a little, carefully release the pusher and then attach the spring to the rear hook.
- Mount the lid from the front; push the lock plunger in as indicated. The lid has to pass.
- Put the three magazine screws in place and push the magazine down. Then first tighten the two front screws.
- Turn the power arm and assemble screw (6/1).

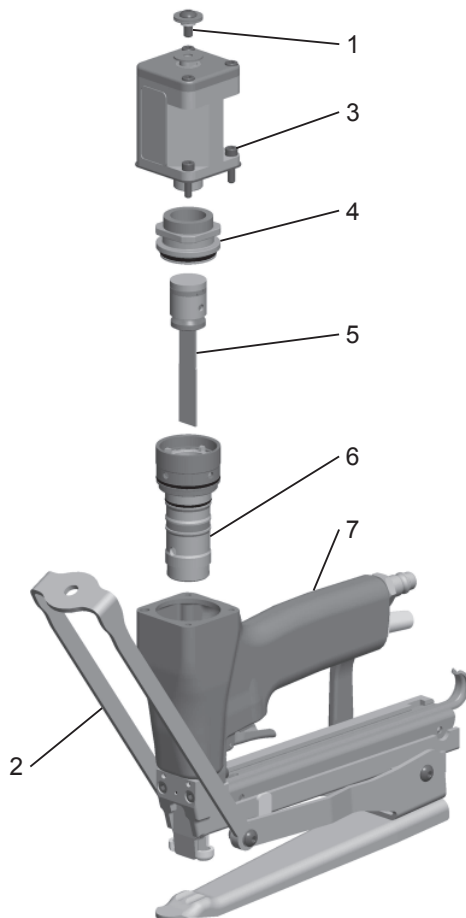

Fig. 7

7.4 CHANGE THE DRIVER BLADE

- Disconnect tool from air supply.
- Dissassemble the screw (Fig. 7/1) holding the power arm (7/2) and turn it underneath the magazine.
- Remove the three screws holding the upper cylinder (7/3) and remove it.
- Remove the cylinder cap (7/4).
- Turn the tool upside down and knock it carefully against a piece of wood to release the driving parts (7/6).
- Remove the driving parts (7/6).
- Disassemble the piston cap (7/5).
- Hold the piston and turn the driver blade a 1/4 turn, remove the pin and replace the driver blade.
- Assemble in opposite way. Do not forget to turn the driver blade a 1/4 turn.
- Grease (Part No 184943) at all O-rings and sliding surfaces. Assemble the piston to the driving part. Enter the driver into the nozzle and push it down. Check that the piston and the driver move freely in the cylinder and in the nozzle.
- Mount the cylinder cap (7/4).
- Mount the upper cylinder (7/3) and tighten the three screws.
- Turn the power (7/2) arm and assemble the screw (7/1).

7.5 CONTROL THE CLINCH

- 1 **Good clinch.**
- 2 Leg length of the staple too long.
- 3 Leg length of staple too short.

 **Always use Josef Kihlberg original staples: JK779-08 up to 16mm.**

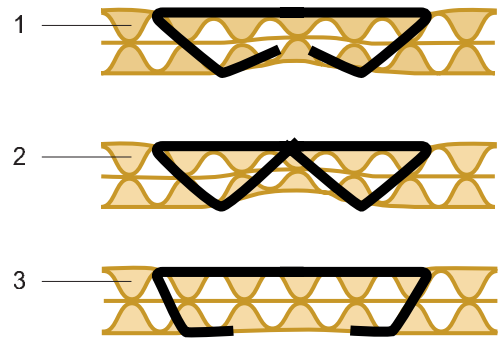

Fig. 8

7.6 ADJUST STAPLE CLINCH

Each plier is tested carefully before delivery. By rough treatment during operation the anvil therefore might need to be adjusted. Uncorrect clinching may then occur (Fig. 9/1).

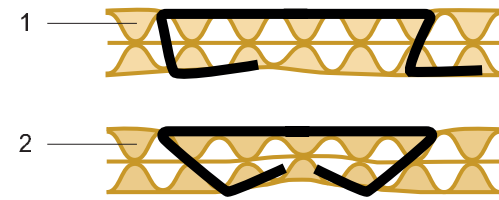

Fig. 9

- Insert a loose staple into the nozzle (Fig.10/1).
- Unscrew the three screws on the rear of the anvil a 1/4 turn. Raise the anvil to the staple edges and adjust it so that the staple hits the anvil hollows symmetrically.
- Then tighten the screws.
- Make a test-stapling in a piece of carton. If the anvil is correct adjusted the clinch should be like in (Fig. 9/2).

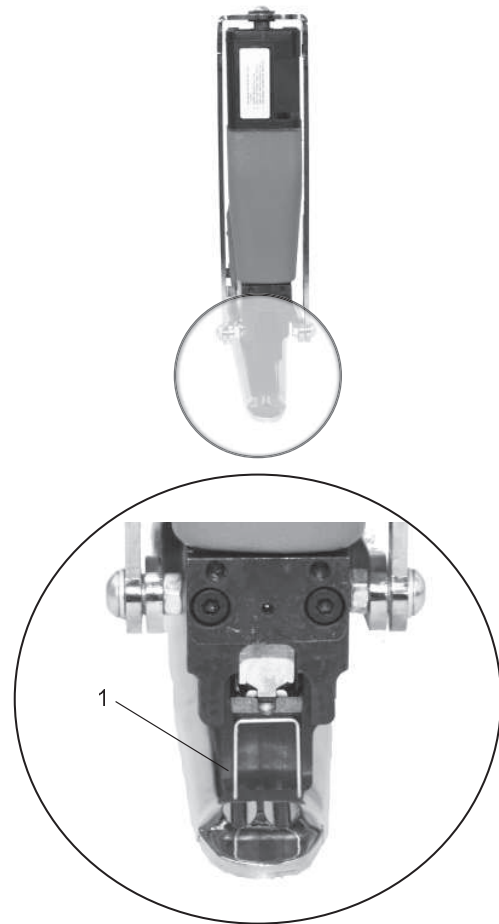

Fig. 10

8

TROUBLE SHOOTING



Before all trouble shooting tasks on the stapler it must first be disconnected from the air supply.

FAULT	ELIMINATION
<p>No staples when firing the tool.</p>	<ul style="list-style-type: none"> – Check that the right type of staples is being used and moves easily inside the rail. – Always use Josef Kihlberg original staples. – Check if the feeder spring is not defective. If necessary replace. – Check if the staple pusher is not defective. If necessary replace. – Clean the staple track. – Air pressure too low. Secure that working pressure is as recommend, see chapter 6.2
<p>Inadequate power. The staples do not penetrate the material sufficiently.</p>	<ul style="list-style-type: none"> – Adjust the air pressure as chapter 6.2 – Has the tool been used without oil? Provide lubrication, see chapter 5.2. – Fit a longer driver blade.
<p>Noise level is too high.</p>	<ul style="list-style-type: none"> – Check if the air pressure is correct. Adjust as per chapter 6.2. – Ensure that the work piece is firmly held in place. Vibration causes high sound levels.
<p>Jammed staple in the nozzle.</p>	<ul style="list-style-type: none"> – Open the door and remove the defective staple, see chapter 7.3.

9

SPARE PARTS KIT / RESERVDLAR SOM DELAR / ERSATZTEIL-SET / JEU DE PIÈCES

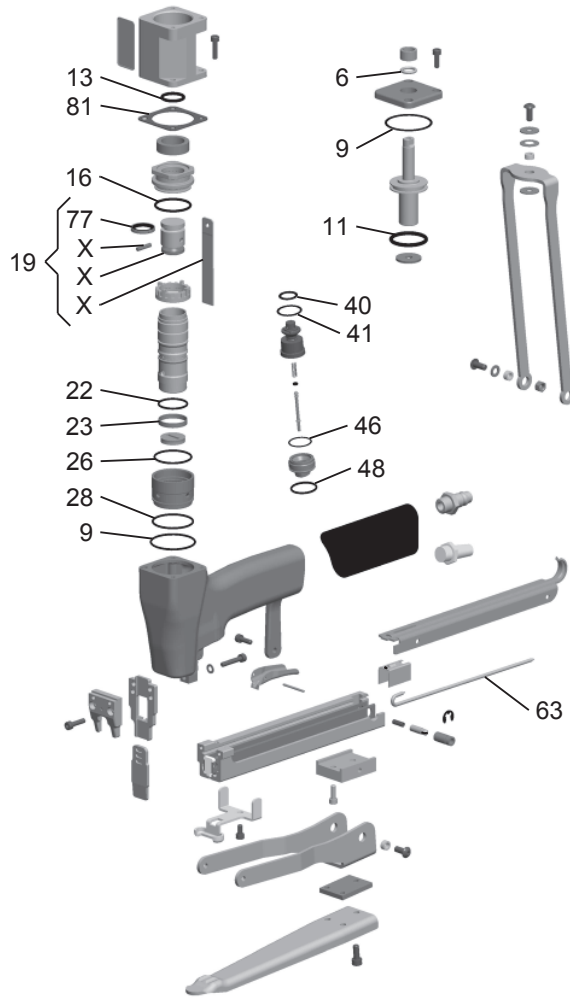

O-ring Kit 143124 (AI JK20 pliers)

Pos.	Part No. Artikelnr.	Part Name	Benämning	Antal Qty.
6	972010	O-ring	O-ring	1
9	972023	O-ring	O-ring	2
11	972018	O-ring	O-ring	1
13	972032	O-ring	O-ring	1
16	972177	O-ring	O-ring	1
22	972028	O-ring	O-ring	3
23	148015	Seal Back valve	Tätningssring backventil	1
26	972007	O-ring	O-ring	1
28	972071	O-ring	O-ring	1
40	972030	O-ring	O-ring	1
41	972039	O-ring	O-ring	1
46	972040	O-ring	O-ring	2
48	972021	O-ring	O-ring	1
77	972124	Set of piston rings	Kolringssats	1
81	148037	Gasket	Packning	1
	184943	O-ring grease	JK silicon compoud	1

Repair Kit 143126 (AI JK20T and JK20V for JK779 staples)

Pos.	Part No. Artikelnr.	Part Name	Benämning	Antal Qty.
6	972010	O-ring	O-ring	1
9	972023	O-ring	O-ring	2
11	972018	O-ring	O-ring	1
13	972032	O-ring	O-ring	1
16	972177	O-ring	O-ring	1
19	134163	Piston cpl. 779	Kolv kpl.	1
22	972028	O-ring	O-ring	3
23	148015	Seal Back valve	Tätningssring backventil	1
26	972007	O-ring	O-ring	1
28	972071	O-ring	O-ring	1
40	972030	O-ring	O-ring	1
41	972039	O-ring	O-ring	1
46	972040	O-ring	O-ring	2
48	972021	O-ring	O-ring	1
63	173053	Feeder spring short	Frammatarfjäder kort	1
63	173054	Feeder spring long	Frammatar fjäder lång	1
77	972124	Set of piston rings	Kolringssats	1
81	148037	Gasket	Packning	1
	184943	O-ring grease	JK silicon compoud	1

10

		Parts list JK20T779L	Reservdelista JK20T779L	Teileliste JK20T779L	
		When ordering please indicate part number	Vid beställning var vänlig ange artikelnumera	Bei Bestellungen immer Artikel-Nr. angeben	
Pos.	Part No. Artikelnr. Artikel-Nr.	Part Name	Benämning	Benennung	Quantity Antal Stückzahl
1	946786	Screw	Skruv	Schraube	5
2	947039	Washer	Bricka	Scheibe	2
3	150257	Spacer	Distansring	Distanzring	1
4	975009	Washer	Bricka	Scheibe	2
5	978022	Bushing	Oljebronsbusning	Buche	1
6	972010	O-ring	O-ring	O-ring	1
7	179034	Cap	Lock	Deckel	1
8	139369	Cap cpl.	Lock kpl.	Deckel kpl.	1
9	972023	O-ring	O-ring	O-ring	2
10	190167	Piston	Kolvstång	Kolben	1
11	972018	O-ring	O-ring	O-ring	1
12	190113	Cylinder	Cylinderfoder	Zylinder	1
13	972032	O-ring	O-ring	O-ring	2
14	149071	Compression washer	Kompressionsbricka	Druckscheibe	1
15	150428	Cylinder cap	Lock för cylinderfoder	Zylinderdeckel	1
16	972177	O-ring	O-ring	O-ring	2
17	145099	Driver pin	Drivarhållarpinne	Stift	1
* 18	164057	Driver blade	Drivare	Antriebsschne	1
* 19	134163	Piston with driver	Kolv kpl. med drivare	Kolben mit Treiber	1
20	150102	Cylinder top ring	Cylindertoppring	Zylinderring	1
21	190066	Cylinder	Cylinderfoder	Zylinder	1
22	972028	O-ring	O-ring	O-ring	3
23	148015	Seal for back valve	Tätningring backventil	Dichtring	1
24	136074	Cylinder with seals	Cylinderfoder med tätningring	Zylinder mit Dichtungen	1
25	149054	Piston stop	Kolvddämpare	Dämpfer	1
26	972007	O-ring	O-ring	O-ring	1
27	150409	Cage	Hylsa	Büchse	1
28	972071	O-ring	O-ring	O-ring	1
30	166216	Rear nozzle plate	Bakre drivarstyrning	Platte hinten	1
32	135613	Front nozzle plate	Främre drivarstyrning	Platte vorne	1
33	946662	Screw	Skruv	Schraube	2
39	166209	Door	Dörr	Abdeckung	1
40	972030	O-ring	O-ring	O-ring	1
41	972039	O-ring	O-ring	O-ring	1
42	191084	Valve cage	Ventilhylsa	Ventilführung	1
43	173066	Spring	Fjäder	Ventilfeder	1
44	972031	O-ring	O-ring	O-ring	1
45	191085	Valve stem	Ventilspindel	Ventilspindel	1
46	972040	O-ring	O-ring	O-ring	1
47	146102	Nut	Mutter	Mutter	1
48	972021	O-ring	O-ring	O-ring	1
50	987023	Nipple	Insticksnippel	Druckluftanschluss	1
51	971004	Sound absorber	Ljuddämpare	Schalldämpfer	1
52	947008	Lock washer	Låsbricka	Sicherungsring	2
53	946512	Screw	Skruv	Schraube	2
54	165040	Trigger	Avtryckare	Abzug	1
55	945039	Tension pin	Spännstift	Ventilfeder	1
56	946608	Screw	Skruv	Schraube	4
57	163342	Power arm	Dragtstång	Zugstange	1
58	150251	Spacer	Distansring	Distanzring	4
59	947012	Washer	Bricka	Scheibe	2
60	946654	Screw	Skruv	Schraube	3
61	170118	Magazine lid short	Magasinslock kort	Magazineckel kurz	1
61	170119	Magazine lid long	Magasinslock lång	Magazineckel lang	1

* Recommended wear parts

* Rekommenderade slitdelar

* Empfohlene Verschleissteile

Pos.	Part No. Artikelnr. Artikel-Nr.	Part Name	Benämning	Benennung	Quantity Antal Stückzahl
62	161208	Pusher	Frammatare	Schieber	1
* 63	173053	Pusher spring short	Frammatarfjäder kort	Magazinfeder kurz	1
* 63	173054	Pusher spring long	Frammatarfjäder lång	Magazinfeder lang	1
64	173052	Lock spring	Låsfjäder	Feder	1
65	160051	Lock piston	Låskolv	Stift	1
66	951037	Retainer	Spärryttare	Sicherungsring	1
67	150121	Lock cage	Spärrhylsa	Büchse	1
68	132686	Rail short	Klammerbana kort	Führung kurz	1
68	132688	Rail Long	Klammerbana lång	Führung lang	1
69	132228	Magazine assembly short	Magasin kpl. kort	Magazin kurz	1
69	132230	Magazine assembly long	Magasin kpl. lång	Magazin kurz	1
70	156955	Rear bracket	Bakre fäste för tunga	Führung	1
71	176616	Bracket	Fäste för tunga	Führung	1
72	157075	Carton protector	Kartongskydd	Kartonabdeckung	1
73	946641	Screw	Skruv	Schraube	1
74	946002	Nut	Mutter	Mutter	2
75	158223	Tongue	Häftunga	Heftzunge	1
76	946654	Screw	Skruv	Schraube	3
77	972124	Set of piston rings	Kolringssats	Kolbenring-Set	1
79	176617	Nut	Mutter	Mutter	2
80	110040	Lable	Etikett	Etikette	1
81	148037	Gasket	Packning	Dichtung	1
84	149089	Bumper	Dämpare	Dämpfer	1
85	035292	Handle sleeve	Gummihandtag	Griffhülse	1

* Recommended wear parts

* Rekommenderade sliddelar

* Empfohlene Verschleissteile

