

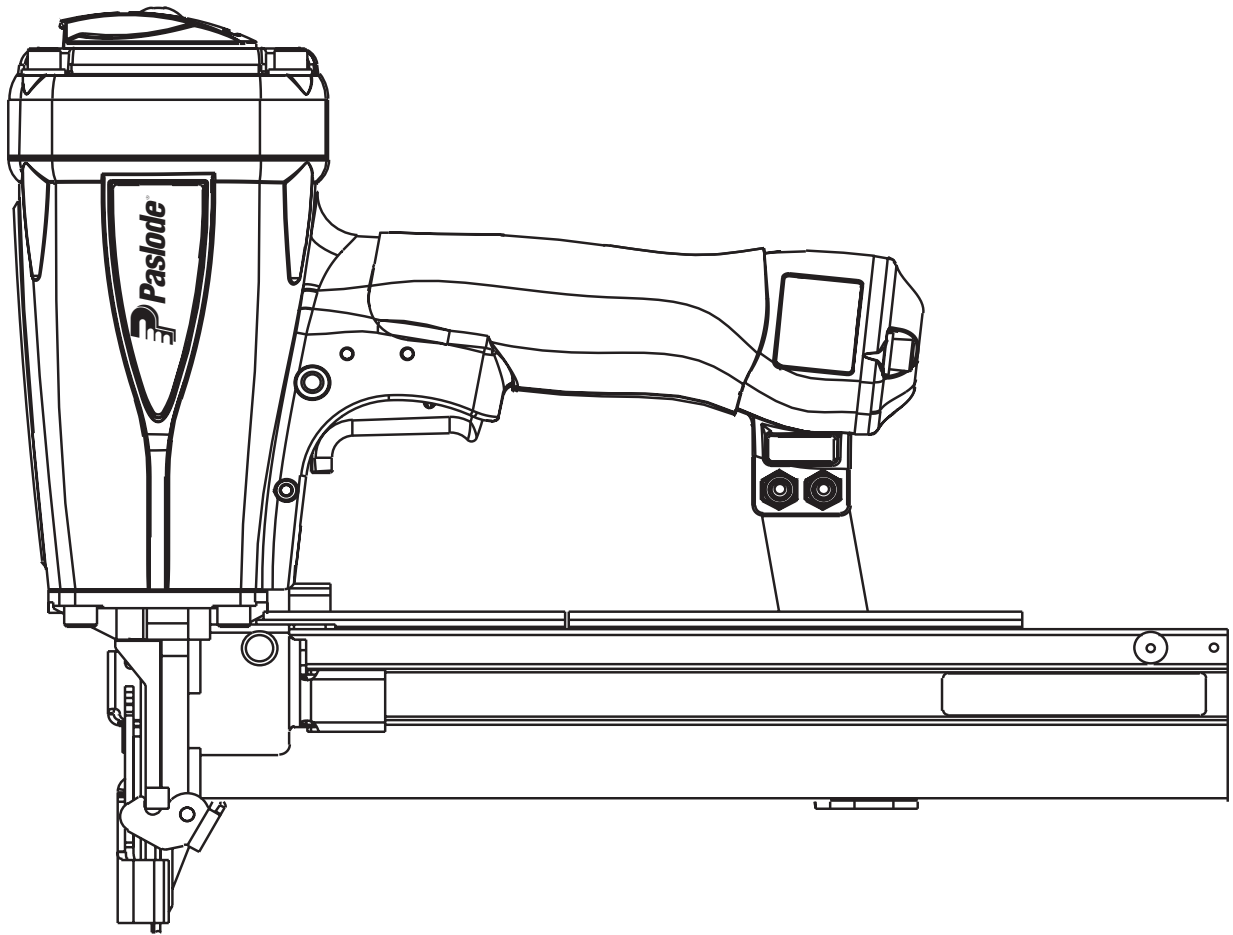

FRAMING STAPLER

MODEL S200-S16
Standard Crown (1/2")



TOOL SCHEMATIC AND PARTS

IMPORTANT! **DO NOT DESTROY**

Always refer to safety and operating manuals, #403606, #405218 and #405222 for detailed information on this tool. It is the customer's responsibility to have all operators and service personnel read and understand this information.

PARTS LEGEND

S200-S16, 501230

1	501043	1	T.H.S.C.S. 1/4-20 x 1/2"	45	401958	1	Valve Body
2	500956	1	Cap Diffuser	46	402668	2	Retaining Washer
3	091362	4	S.H.C.S. 1/4-20 x 1-1/2"	47	501008	1	Trigger Lever
4	092757	4	Flat Washer	48	501010	1	Trigger
5	501231	1	Cap	49	501009	1	Roll Pin
→ 6	514892	1	Conical Spring	50	402669	1	Trigger Pin
* 7	404230	1	Retaining Ring	51	092037	4	Locknut
8	501250	1	Upper Valve Piston	52	004502	2	S.H.C.S. 10-32 x 5/8"
* 9	091542	1	O-Ring	53	402781	1	Rail Bracket
10	404054	1	Seal, Main Valve	▲ 54	004224	3	S.H.C.S.10-32 x 3/8"
11	404056	1	Lower Valve Piston	55	402743	1	Pin Negator Drum
* 12	090927	1	O-Ring, Main Valve	56	091534	1	Drum, Negator
* 13	092775	1	O-Ring, Main Valve	57	091532	1	Negator
* 14	092773	1	O-Ring, Main Valve	▲ 58	091568	1	Bd. Head Screw 6-32 x 1/4"
* 15	404256	2	O-Ring	59	402796	1	Follower
16	500954	1	Post, Main Valve	60	402797	1	Retaining Bushing
17	015660	1	S.H.C.S. 10-24 x 1/2"	61	402798	1	Latch Follower Button
18	403582	1	Driver Blade Nut	62	402799	1	Spring Follower Latch
* 19	405430	1	O-Ring, Piston	63	402740	2	Roll Pin 3/32 x 7/16
20	501169	1	Piston	64	402780	1	Pivot Rail Cover Assembly
* 21	403202	1	Driver Blade	65	501226	1	Nameplate
22	501322	1	Sleeve Retainer	66	403427	1	Rail & Rail Cover Assembly
23	402725	1	Seal Sleeve	** 67	500459	1	Warning Label
24	405243	1	Flange Sleeve	68	404698	2	Roll Pin Assembly
25	501228	1	Sleeve	69	402730	1	Pivot Pin Front Guide
* 26	402728	1	O-Ring, Sleeve	70	405079	1	Spring Front Guide Latch
* 27	091966	1	O-Ring, Sleeve	71	403206	1	Latch Front Guide
* 28	500369	2	O-Ring, Sleeve	72	092176	1	Roll Pin 5/32 x 1-3/8"
29	501227	1	Bumper Retainer	73	403205	1	Back Plate
30	500975	1	Gasket Cap	74	404232	2	S.H.C.S. 8-32 x 13/16"
31	501140	1	Logo Housing Left	75	403204	1	Front Guide
32	501141	1	Logo Housing Right	76	402734	1	Spring
33	402708	1	Gasket Nose Flange	77	402792	1	Intermediate W.C.E.
34	501229	1	Bumper	78	402629	2	Hardened Washer
35	402785	1	Seal Driver Blade	79	403716	2	S.H.C.S. 10-32 x 5/16"
36	402706	1	Flange	80	501780	1	Lower W.C.E.
37	091545	4	S.H.C.S. 1/4-20 x 7/8"	81	402736	1	Flat Washer
38	501023	1	Grip Handle	82	402738	1	Spring
39	500957	1	Housing	83	501320	1	Guide Block
40	500963	1	End Plug	84	501243	1	Upper W.C.E.
41	097748	1	Spring Valve Pin	85	071297	1	Roll Pin 1/8 x 1-1/8"
42	097746	1	Valve Pin	86	501299	2	S.H.C.S. 1/4-20 x 1"
* 43	092174	1	O-Ring, Valve Body				
44	026133	2	Roll Pin 1/8 x 1				

* Denotes normal wear items.

** Make sure warning label (500459) is properly affixed.
Replace if necessary.

▲ Apply Loctite 242 (Blue)

→ Denotes new change

Fastener sizes:

Length: 3/4" to 2"

Gauge & Crown: 16 ga. 1/2" Crown

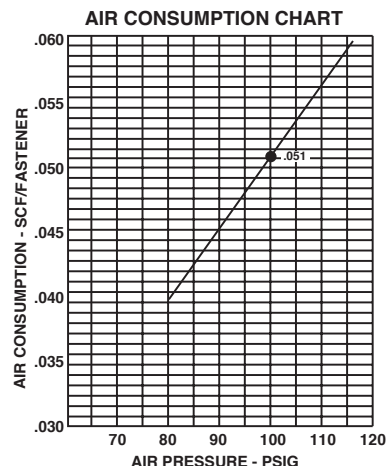

S200-S16

501230

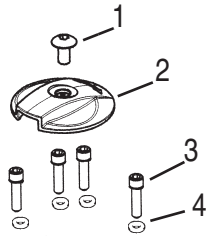

Cap Assembly #501263

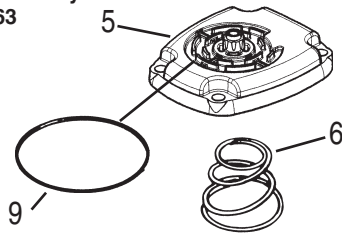

Main Valve Assembly #501261

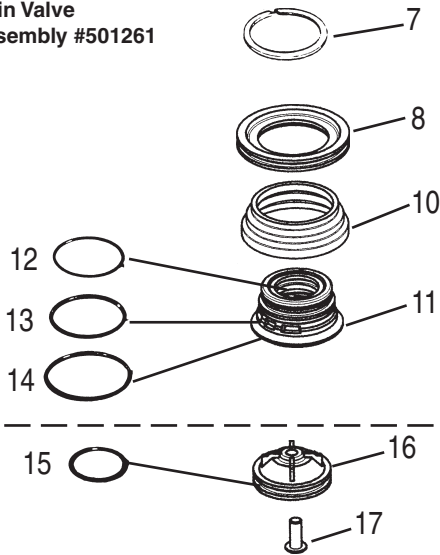

Piston Assembly #501266

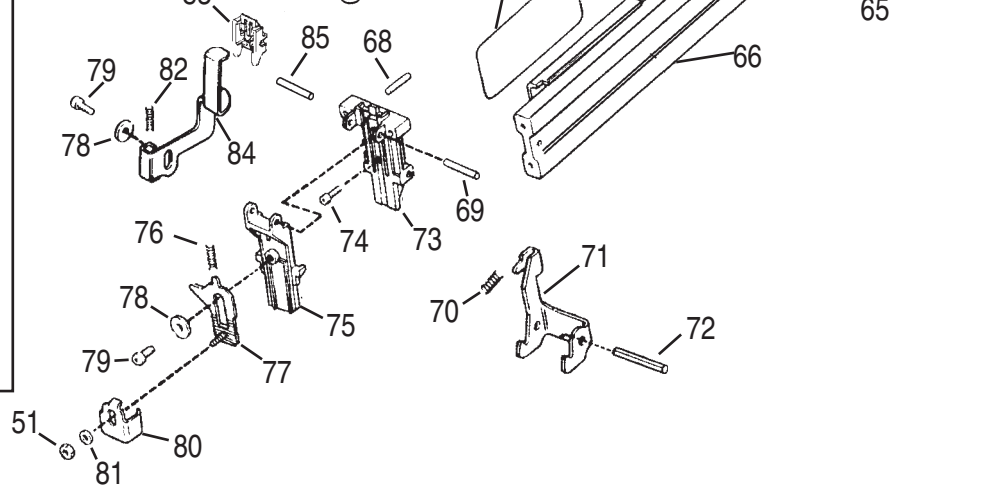
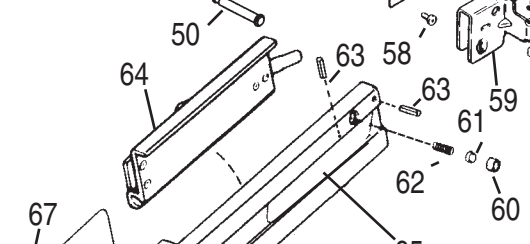
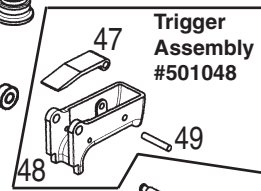
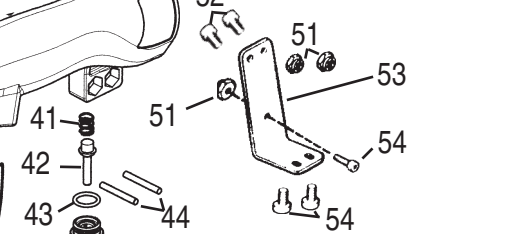
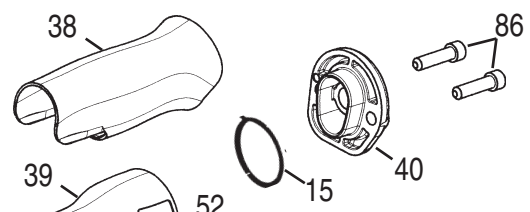
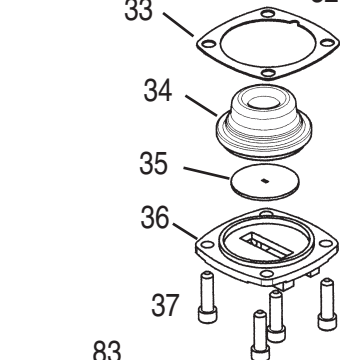
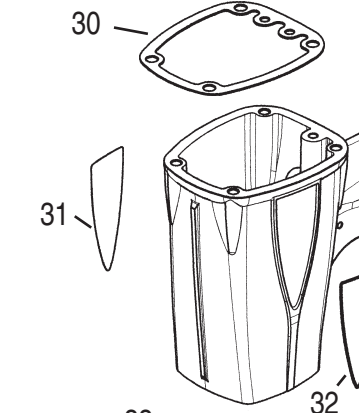
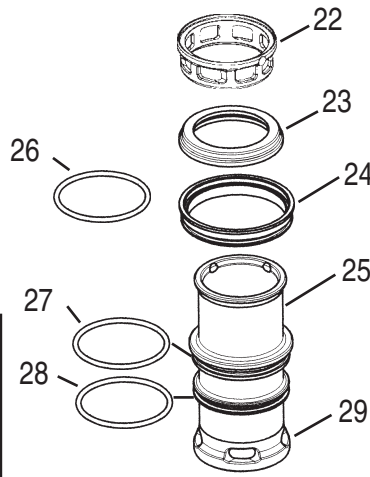
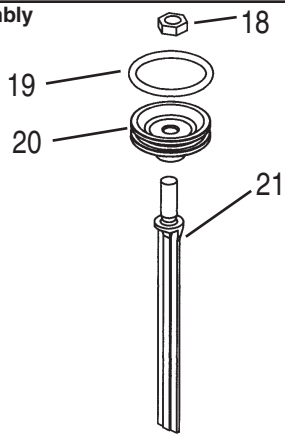

WARNING

All parts must be periodically inspected and replaced if worn or broken. Failure to do this can affect the tool's operation and present a safety hazard.

ACCESSORIES

Sequential Operating Kit

This special attachment is designed for sequential operation (stops "contact" firing). The operator must depress and hold the work contacting element against the worksurface before pulling the trigger. This sequence must be repeated each time the tool drives a fastener.

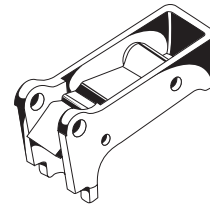

Part No. 501039

Remote Fire Valve

This valve via a positive air signal allows a machine mounted tool to be operated from an automatic air valve or foot pedal system.

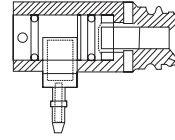

Part No. 1X0713

Lubricants and Loctite

Chemplex 710 Lubricant 1 lb.

Part No. 403734

Lubricant 5 gram tubes

Part No. 219188

Loctite 242 (Blue) 1 oz.

Part No. 093500

Lubricating Oil 16 oz.

Part No. 403720

Lubricating Oil 8 oz. with Antifreeze

Part No. 219090



Belt Hook

Attaches to tool enabling you to carry tool on your belt.

Part No. 500955

Tool Cleaner

Ideal cleaner for all Paslode tools.

Part No. 219348



Safety Glasses

Clear



Part No. 401382

Vinyl Siding Work Contacting Element

This attachment allows the WCE to be adjusted to ensure the gap between the staple and siding.

This enables positive placement of staple leg in center of siding slot which eliminates cracking.



Part No. 219051

Trigger Valve Repair Kit

This kit repairs all trigger valve air leaks.

Part No. 219224

SAFETY INSTRUCTIONS

WEAR EYE AND HEARING PROTECTION



Always wear hearing protection and eye protection devices, including side shields when operating or working in the vicinity of a tool.

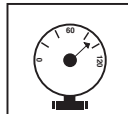
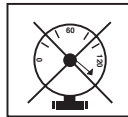

DO NOT EXCEED MAXIMUM
RECOMMENDED AIR PRESSURE

Operate the tool using only the recommended air pressure. Do not exceed the maximum air pressure marked on the tool. Be sure the air pressure gauge is operating properly and check it at least twice a day.

Never use any bottled air or gases such as oxygen to operate the tool since they could cause the tool to explode.



An Illinois Tool Works Company
155 Harlem Avenue
Glenview, IL 60025

Printed in U.S.A.
© 2017 Illinois Tool Works, Inc.

501349-10
02/17