

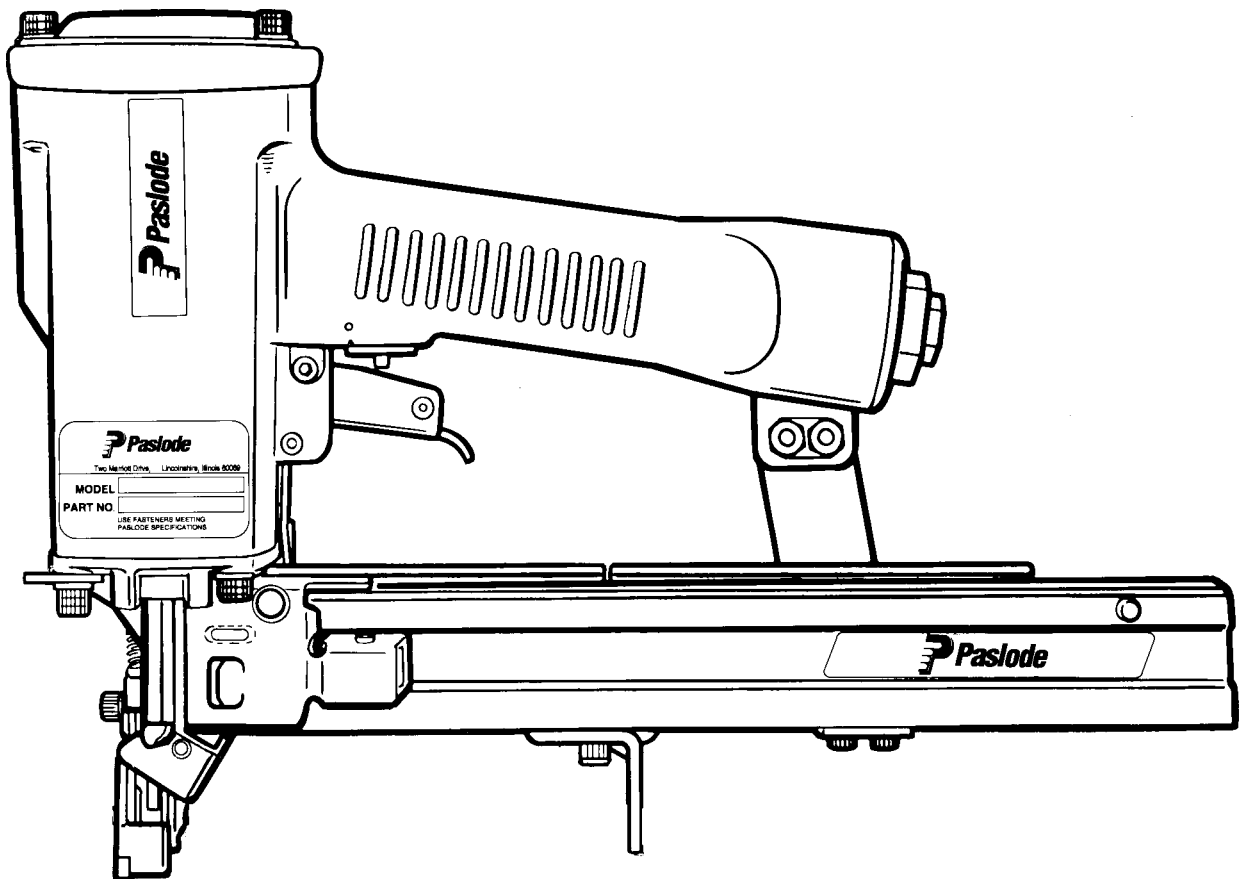

MODEL 3150/38 W16R
STAPLER



TOOL SCHEMATIC AND PARTS

IMPORTANT!
DO NOT DESTROY

Always refer to safety and maintenance manual #403606 for detailed information on this tool. It is the customer's responsibility to have all operators and service personnel read and understand this information.

PARTS LEGEND

3150/38 W16R, 402700

1	092735	4	Socket Head Capscrew, 1/4-20 x 1-1/4"	47	402741	1	Rail Bracket
2	002187	4	Lock Washer, 1/4"	48	004224	6	Socket Head Capscrew, #10 - 32 x 3/8"
3	402726	1	Air Deflector	50	402629	2	Hardened Washer
4	006310	1	Socket Head Capscrew, #6-32 x 1/2"	51	402737	1	Intermediate Work Contacting Element
6	402704	1	Cap	*52	402738	1	Spring
7	402717	1	Conical Spring	*53	092773	1	"O" Ring
8	404230	1	Retaining Ring	54	404699	1	Lower Work Contacting Element
*9	091537	1	"O" Ring, Main Valve Assembly	55	404056	1	Lower Valve Piston
10	404122	1	Upper Valve Piston	*56	402734	1	Spring
11	404055	1	Post Main Valve	57	402756	1	Front Guide
*12	404256	1	"O" Ring, Main Valve Post	59	404698	2	Roll Pin Assembly
*13	402723	1	"O" Ring, Piston	60	404843	1	Back Plate
14	403563	1	Piston	61	402730	1	Pivot Pin, Front Guide
15	403582	1	Jam Nut	62	402762	1	Roll Pin, 5/32" Dia. x 1-3/4" Lg.
*16	404182	1	Driver Blade	63	405078	1	Spring, Front Guide Latch
17	402725	1	Seal, Sleeve	64	402761	1	Latch, Front Guide
18	405245	1	Sleeve	65	402486	1	Retaining Washer
*19	402728	1	"O" Ring, Sleeve	**66	500457	1	Warning Sign
*20	402729	1	"O" Ring, Sleeve	67	402748	1	Pivoting Rail Cover Assembly
21	403854	1	Retainer, Bumper	68	404848	1	Rail and Rail Cover Assembly
*22	403855	1	Bumper	69	402731	1	Logo, Rail
23	402754	1	Seal, Driver Blade	70	402740	1	Roll Pin, 3/32" Dia. x 7/16" Lg.
*24	402707	1	Gasket, Cap	71	402758	1	Latch, Follower
25	402701	1	Housing	72	402759	1	Spring, Follower Latch
26	404939	2	Logo, Housing	73	091568	1	Binding Head Screw, #6-32 x 1/4"
27	096893	1	Nameplate	*74	091532	1	Negator
*28	402708	1	Gasket, Flange	75	091534	1	Drum, Negator
29	402706	1	Flange	76	402743	1	Pin, Negator Drum
30	091545	4	Socket Head Capscrew, 1/4-20 x 7/8"	77	402760	1	Follower
31	405144	1	Trigger	78	402782	2	Wear Shield, Cap
32	402079	1	Pin, Trigger	79	402783	2	Wear Plate, Flange
33	402668	1	Retaining Washer	80	402769	1	Shingle Guide
34	404054	1	Seal Main Valve	81	403211	1	Rail Wear Button
*35	090927	1	"O" Ring	82	404325	1	Stop Nut
*36	092775	1	"O" Ring	83	091447	4	Flat Washer, 1/4"
37	026133	2	Roll Pin, 1/8" Dia. x 1" Lg.	86	092037	1	Flexloc Nut #10-32
38	401958	1	Valve Body	87	402736	1	Flat Washer
*39	092174	1	"O" Ring, Valve Body	88	402765	1	Lower Work, Contacting Element
40	097746	1	Valve Pin	89	402763	1	Upper Work, Contacting Element
41	097748	1	Spring, Valve Pin	90	405147	1	Lever, Trigger
42	091591	1	"O" Ring, End Plug	91	005849	1	Roll Pin
43	401940	1	End Plug	93	091966	1	"O" Ring
44	091622	1	Reducing Pipe Bushing	94	405243	1	Flange, Sleeve
▲ 45	004502	4	Socket Head Capscrew, #10-32 x 5/8"	95	500488	1	Grip, Handle
46	092037	6	Flexloc Nut, #10-32	96	403716	2	Socket Head Capscrew 10-32 x 5/16"

* Denotes normal wear items.

** Make sure warning label (500457) is properly affixed.
Replace if necessary. Label available at no charge through
the Service Dept.

▲ Apply Loctite 242 (Blue) Part No. 093500

➔ Denotes new change.

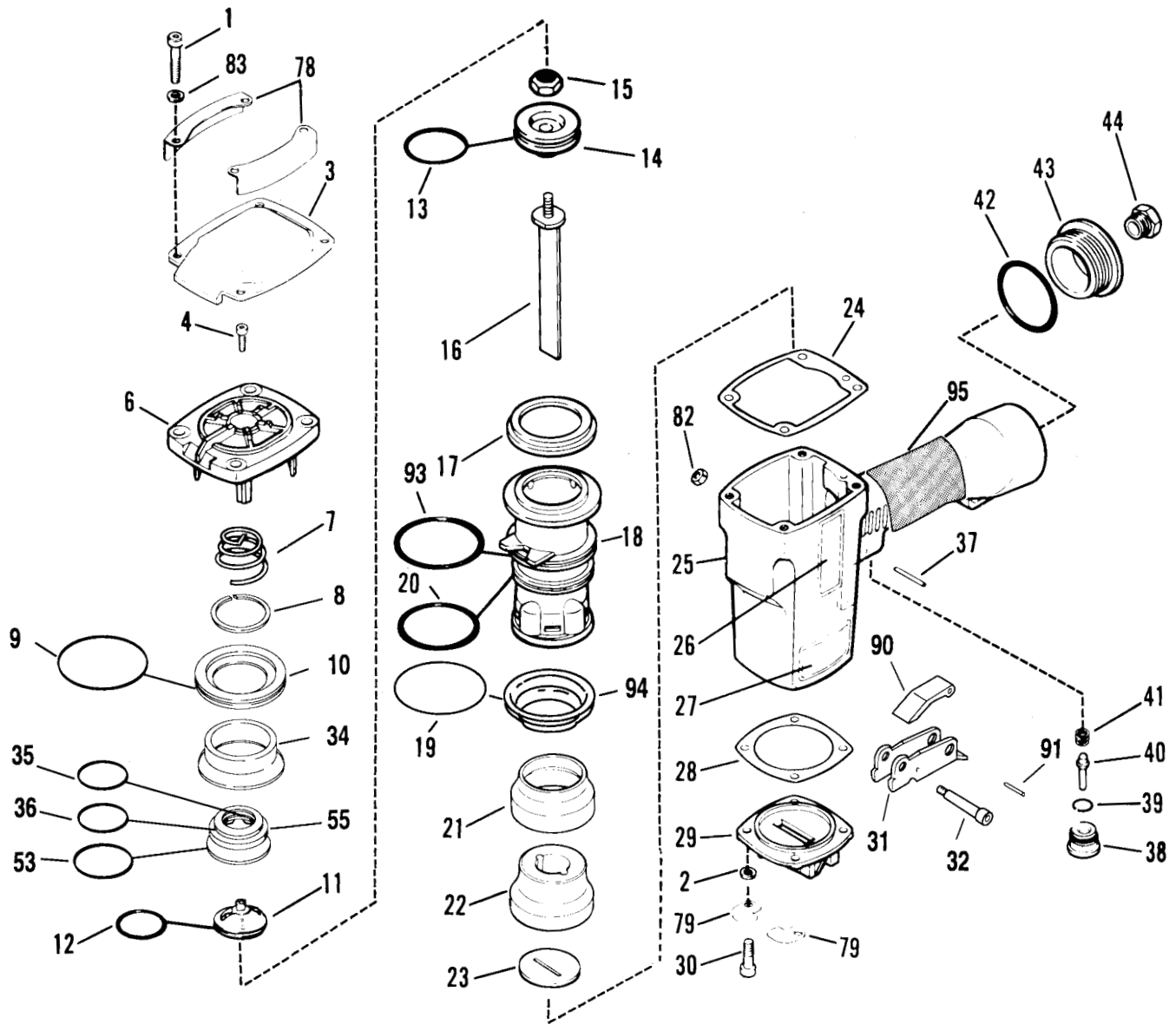

WARNING

All parts must be periodically inspected and replaced if worn or broken. Failure to do this can affect the tool's operation and present a safety hazard.

3150/38 W16R

402700

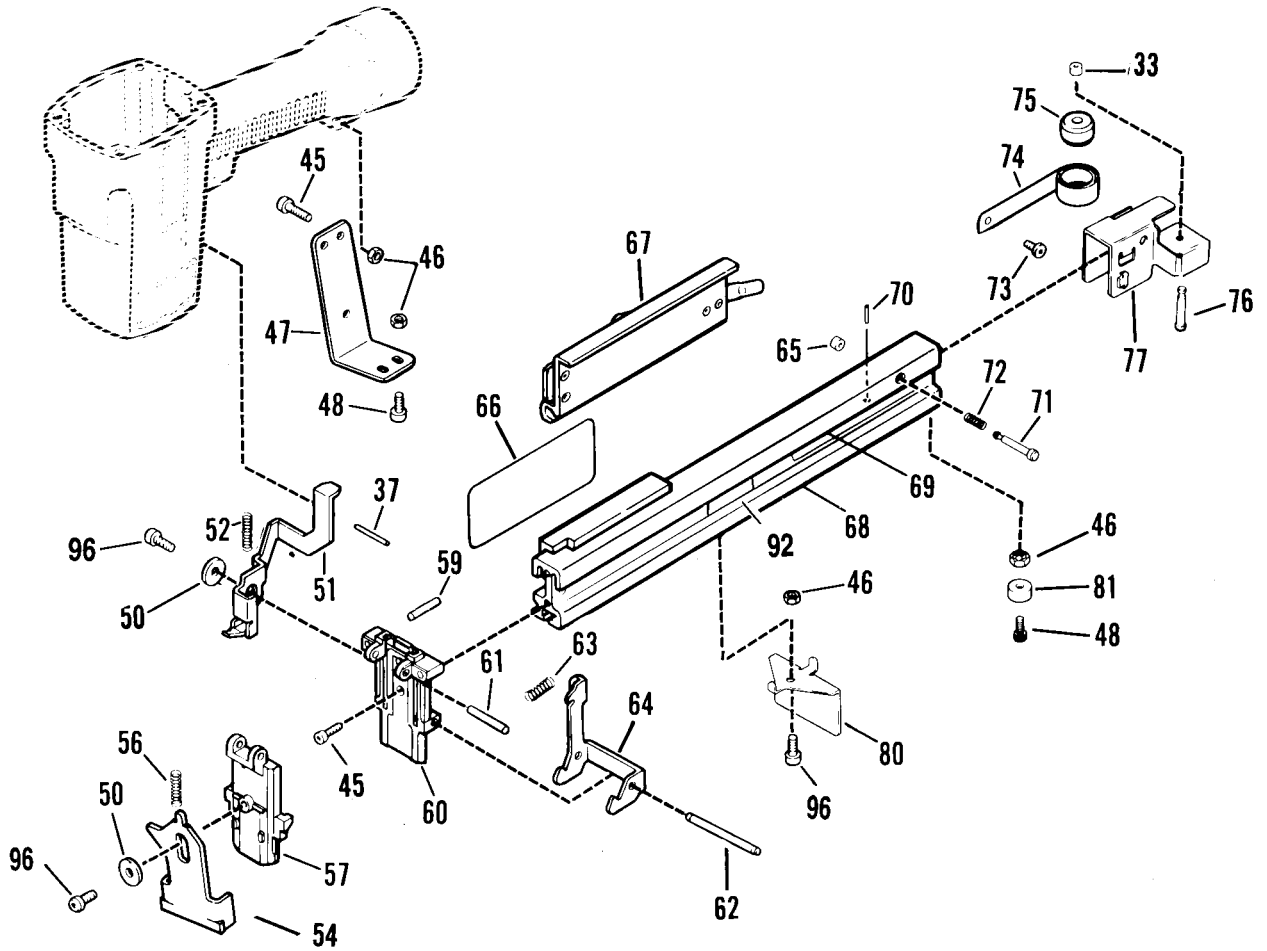

OPTIONAL:

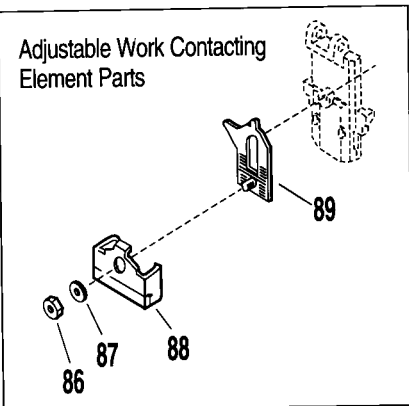

PARTS OFFERED AS ASSEMBLIES

404345 Piston Assembly

Includes

*13	402723	1	"O" Ring, Piston
14	403563	1	Piston
15	403582	1	Jam Nut
16	404182	1	Driver Blade

402408 Trigger Assembly

Includes

31	405144	1	Trigger
90	405147	1	Lever, Trigger
91	005849	1	Roll Pin

404188 Main Valve Assembly

Includes

8	404230	1	Retaining Ring
*9	091537	1	"O" Ring, Main Valve Assembly
10	404122	1	Upper Valve Piston
34	404054	1	Seal, Main Valve
*35	090927	1	"O" Ring, Main Valve Assembly
*36	092775	1	"O" Ring, Main Valve Assembly
*53	092773	1	"O" Ring, Main Valve Assembly
55	404056	1	Lower Valve Piston

402709 Cap Assembly

Includes

4	006310	1	Socket Head Capscrew, #6-32 x 1/2"
6	402704	1	Cap
7	402717	1	Conical Spring
11	404055	1	Post, Main Valve
12	404256	1	"O" Ring, Main Valve Post
	404188	1	Main Valve Assembly

AIR CONSUMPTION CHART

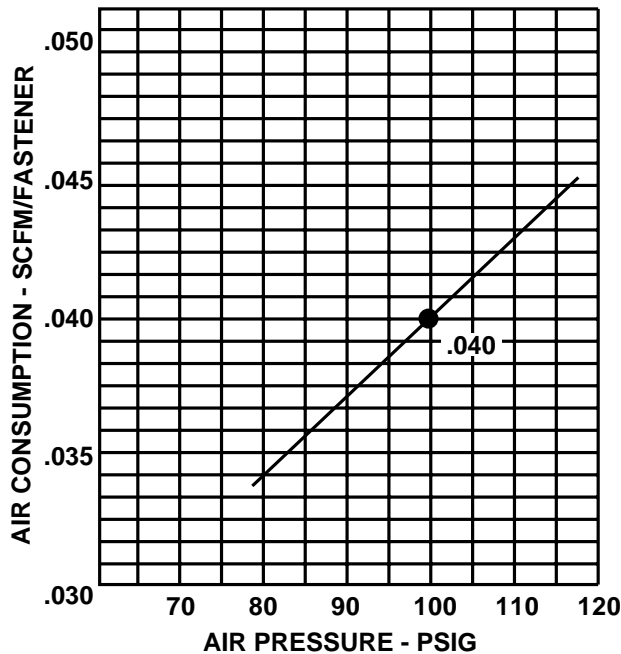

SAFETY INSTRUCTIONS

WEAR EYE AND HEARING PROTECTION

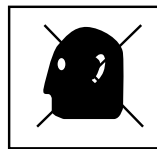

Always wear hearing protection and eye protection devices, including side shields when operating or working in the vicinity of a tool.



DO NOT EXCEED MAXIMUM RECOMMENDED AIR PRESSURE

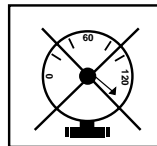

Operate the tool using only the recommended air pressure. Do not exceed the maximum air pressure marked on the tool. Be sure the air pressure gauge is operating properly and check it at least twice a day.

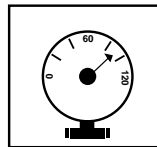

Never use any bottled air or gases such as oxygen to operate the tool since they could cause the tool to explode.

ACCESSORIES

Sequential Operating Kit

This special attachment is designed for sequential operation. The operator must depress and hold the work contacting element against the work surface before pulling the trigger. This sequence must be repeated each time the tool drives a fastener.

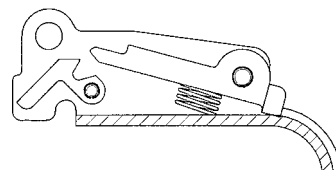

Part No. 406006

ACCESSORIES *Continued*

Remote Fire Valve

This valve via a positive air signal allows a machine mounted tool to be operated from an automatic air valve or foot pedal system.

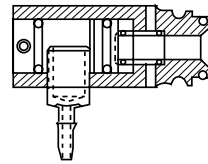

Part No. 1X0713

Adjustable Foam Contacting Element

This is a wide-foot, cast and brazed assembly that replaces the standard 3000-W16 series work contacting element. This assembly is intended for foam sheathing applications and on machine-mounted tools.

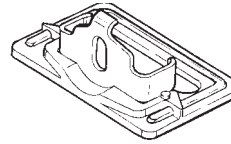

Note: Must be used in combination with #402763 - upper WCE.

Part No. 402997

Rear Activating Foam Contacting Element

This is a rear-activating, welded-wire work contacting element. It replaces the standard 3000-W16 series work contacting element where rear activation is needed.

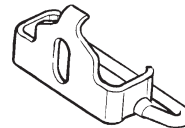

Part No. 1X1026

Heavy Duty Single Guide

A larger surface shingle guide for the 3150-W16R to improve the balance of the tool when used on roofing applications. Also allows proper placement of fastener into shingle.



Part No. 1X1227

Lubricants and Loctite

Loctite 242 (Blue) 1 oz	Part No. 093500
→ Lubricating Oil 16 oz.	Part No. 403720
Lubricating Oil with Antifreeze	Part No. 219090
Chemplex 710 Lubricant 1 lb.	Part No. 403734

Wide Crown Stapler Repair Kit

This kit repairs all air leaks except for the trigger valve.

Part No. 219222

Degreaser Cleaner

Ideal Cleaner for all Paslode Tools Part No. 219086

Trigger Valve Repair Kit

This kit repairs all trigger valve air leaks.
Part No. 219224

Belt Hook

Attaches to cap of tool enabling you to carry tool on belt holder. Part No. 219017

Safety Glasses

Clear Part No. 402510
Tinted Part No. 402512

Belt Hook Holder

Attaches to work belt and carries tool using the above belt hook. Part No. 219028

Large Nylon Tool Bag

Soft-sided heavy duty nylon tool bag ideal to protect your tool. Part No. 219246 ←