

STANLEY-BOSTITCH MODEL D16-2 BOXLOK STAPLER PARTS CHART

- 2 -

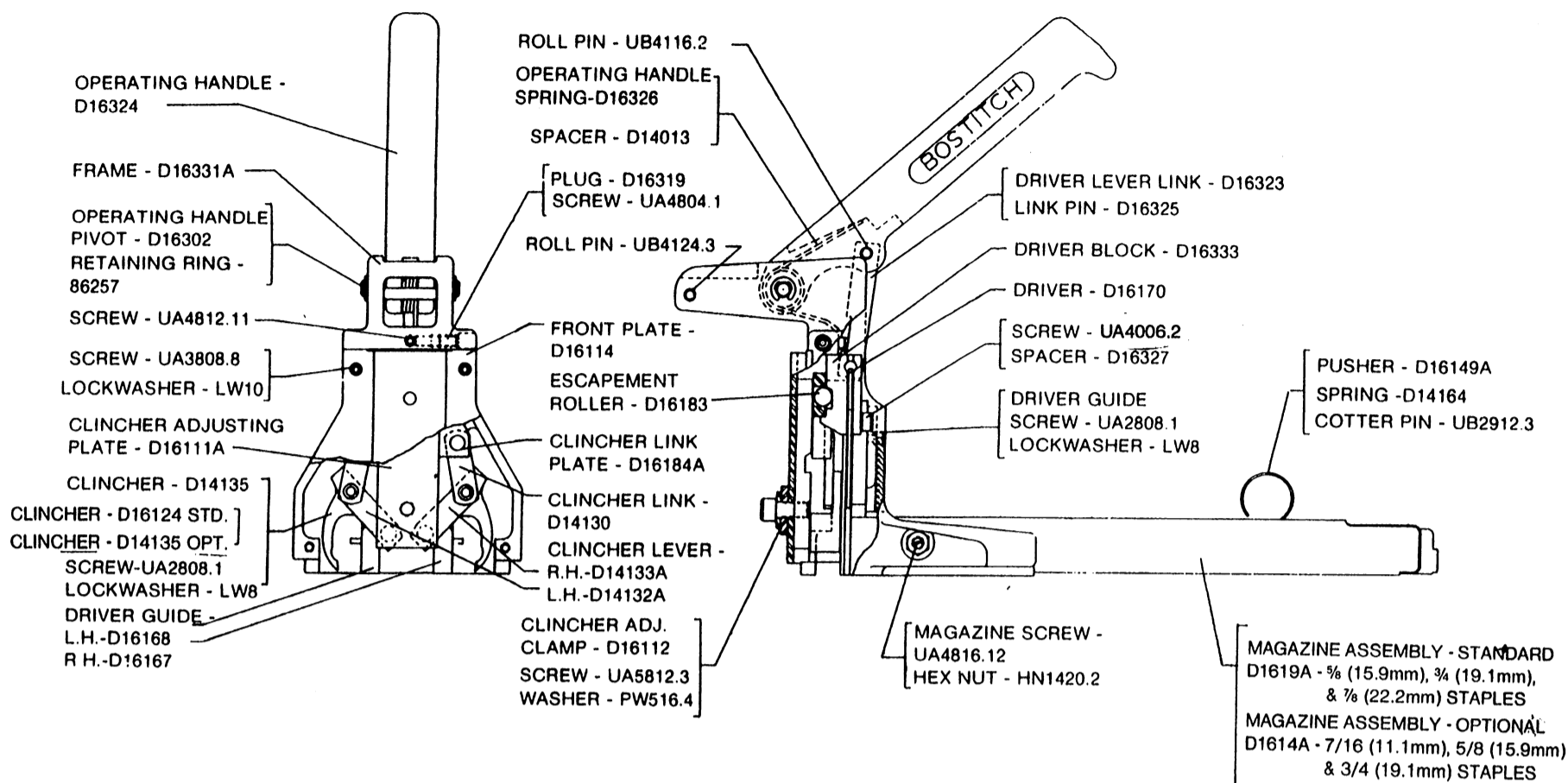

grasp and strike a load of staples with high speed. This will deform some staples, and they may not feed properly. This condition usually results if the pusher is improperly released when the magazine is half or less than half filled.

CAUTION:

DO NOT ALLOW THE PUSHER TO SLIP FROM GRASP AND STRIKE THE FRONT END OF THE MAGAZINE WHEN EMPTY; SUCH ACTION MAY RESULT IN DAMAGE TO THE FRONT END OF MAGAZINE AND PUSHER.

To operate machine, grasp firmly with both hands usually with left hand resting on top front of frame and operating handle in right hand. Position

on box to be stapled by placing magazine directly over the seam between flaps and in line with desired staple location. The sides of the frame are notched as an aid in positioning staple. Press handle all the way down with a quick firm stroke and then pull up to the top. Move machine to each staple position and repeat. At least half of the magazine should rest on the box being stapled to insure necessary stability. Strongest closure requires end staples quite close to end of box - approximately 1" (25.4mm) is desirable. Be sure other staples penetrate inner flaps. Check staple clinching in samples of box board such as that being used. Adjustment for depth of penetration is easy and instantaneous and full advantage should be taken of it. Clincher adjusting clamp setting as listed in chart is offered merely as a guide and may have to be modified slightly.

MAINTENANCE

LUBRICATION:

Oil internal working parts, occasionally, through bottom and back of head. A little machine oil should be applied to the operating handle pivot, driver lever link pivot and the pusher spring roll pivot in the magazine.

REPLACEMENT OF CLINCHERS:

To replace clinchers, proceed as follows:

1. Loosen the clincher adjusting clamp screw.
2. Slide the clincher adjusting clamp up to the highest position. Retighten clamp screw. The clincher screws will be aligned with and visible through the 2 round holes in the back of machine frame. Insert a socket screw wrench to loosen and remove screw holding clincher.
3. Grasp the clinchers by hand or with pliers and lift off the anchor dowels.
4. Insert new clincher and screw. Tighten screw firmly.
5. Readjust the clincher adjusting clamp to the desired setting and tighten.

REMOVING AND REPLACING THE MAGAZINE:

1. Remove staples from magazine.
2. Loosen the magazine binding screws and nuts.
3. Pull magazine back and out of engagement with the frame.
4. Insert new magazine making sure the front edge contacts the rear of driver guides. Centralize magazine in driver guides with binding screws. Then tighten the magazine binding screws and nuts to a point where magazine is securely held with no movement. Caution: Do not tighten the magazine binding screws excessively as too much pressure will damage the magazine.

TO DISASSEMBLE AND ASSEMBLE DRIVER:

1. Remove the magazine.
2. Tip machine forward and rest on frame.
3. Grasp top back portion of frame with left hand and with thumb of left hand exert pressure against the driver block.
4. Remove the driver retaining screw. Driver may now be removed from the housing.
5. Maintain pressure against the driver block while removing and until driver is replaced.

- 3 -

OPERATION and MAINTENANCE MANUAL

MODEL D16-2 BOXLOK STAPLER

STAPLE SIZES: SW7437 7/16 (11.1mm), 5/8 (15.9mm), 3/4 (19.1mm)
—SW9040 7/16 (11.1mm), 5/8 (15.9mm), 3/4 (19.1mm), 7/8 (22.2mm)

CAUTION: Read instructions carefully before operating machine.

▲ WARNING:
KEEP HANDS AND BODY AWAY FROM CLINCHERS.

OPERATION

CHOICE OF STAPLE SIZE:

Refer to charts as a guide for establishing proper staple leg length and approximate clincher depth setting.

NOTE: A 1/32" (.78mm) difference in settings from those shown in the below listed charts may be obtained by rotating the D16112 clamp 1/2 turn or 180°.

D14135 CLINCHERS

| Approx. Clincher Adjusting Clamp Setting. | 6 | 5 | 4 | 3 | 2 | 1 |
|--|---|-------------------------|------------------------|------------------------|------------------------|---|
| (2)A Board-Blind | | | | 5/8 (15.9mm) Leg | | |
| (2)A Board-Through | | | | | 3/4 (19.1mm) Leg | |
| (2)B Board-Blind | | 7/16 (11.1mm) Leg | | | | |
| (2)B Board-Through | | | 5/8 (15.9mm) Leg | | | |
| (2)C Board-Blind | | | 7/8 (11.1mm) Leg | | | |
| (2)C Board-Through | | | | 5/8 (15.9mm) Leg | | |

D16124 DEEP CLINCHERS

| Approx. Clincher Adjusting Clamp Setting. | 6 | 5 | 4 | 3 | 2 | 1 |
|--|---|---|---|---|---|------------------------|
| (2)A Board-Through | | | | | | 3/4 (19.1mm) Leg |
| (2)AB Board-Blind | | | | | | 3/4 (19.1mm) Leg |
| (2)AB Board-Through | | | | | | 7/8 (22.2mm) Leg |

D14135 clinchers are for shallow penetration as in single wall board and should clinch inside board without damage to contents. D16124 clinchers are for deep penetration as in double wall board. **CAUTION: —WHEN USING DEEP PENETRATION CLINCHERS, IT MAY BE NECESSARY TO USE A FILLER TO PREVENT DAMAGE TO MERCHANDISE.** D16124 clinchers may also be used for stapling through single wall board providing a filler is used to prevent damage to contents or clinchers.



Staple driven completely through two thicknesses of corrugated board and clinched on underside.



Staple clinched "blind," when desired, in two thicknesses of corrugated board.

To obtain maximum efficiency from the staple closure, it is important that the staple be properly clinched. Properly clinched staples for any thickness of board as illustrated, may be obtained by adjusting the clincher setting and using staples of proper leg length.

CLINCHER ADJUSTMENT:

Clincher adjustment for depth of penetration is obtained by loosening the clincher adjusting clamp screw on front of machine and moving the clincher adjusting clamp up or down. When the clincher adjusting clamp is in its highest position the clinchers are set for the shallowest staple penetration. As the clincher adjusting clamp is lowered, the depth of penetration is increased. After establishing the clincher depth setting, tighten the clincher adjusting clamp screw.

DRIVER ADJUSTMENT:

The driver may be adjusted for countersinking the crown of the staple below the surface of the box or adjusted to allow the crown of the staple to rest against the top surface of the box.

To adjust, remove staples. Turn machine upside down exerting enough pressure against the bottom of the magazine to insure the operating handle is all the way down.

▲ WARNING: KEEP HANDS AWAY FROM CLINCHERS

Loosen set screw UA4804.1. Turn stop screw UA4812.11 until desired adjustment of driver is obtained. Tighten set screw UA4804.1.

TO LOAD:

Pull Pusher to back of magazine and turn down over rear as far as it will go. Place 2 sticks of SW7437 or SW9040 staples in staple channel. Swing pusher into place against staples. Do not let pusher slip from