

F21PL

PNEUMATIC STICK NAILERS

CLAVADORA NEUMÁTICA ALIMENTADA POR BARRA

CLOUEUR PNEUMATIQUE EN BANDES

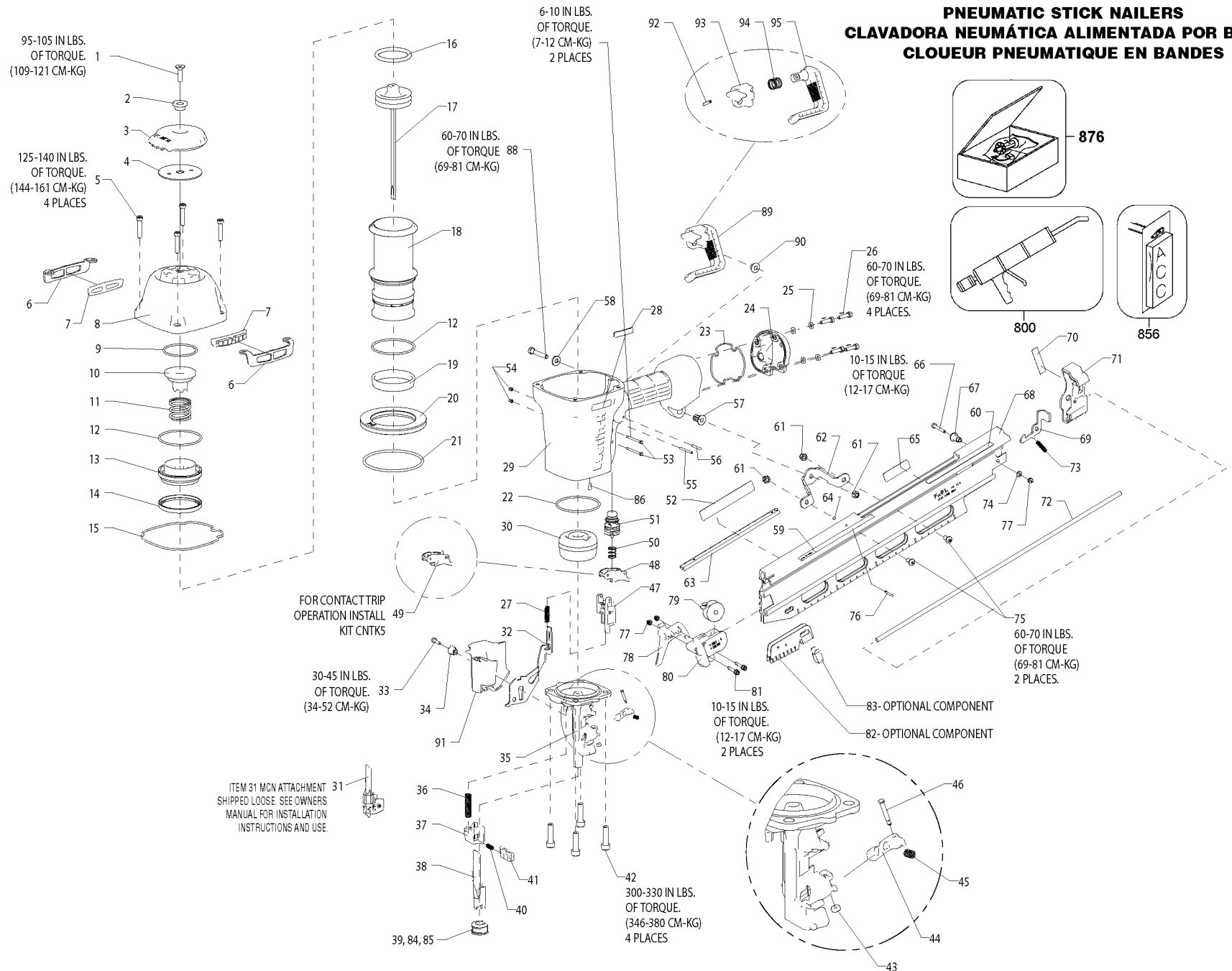

Parts List for F21PL Type 0

Item Number	Part Number	Description	Qty Required
1	MSF6100-25	SCREW-SFHCS-M6X1.00X	1
2	163859	BUSHING-EXHAUST DEFL	1
3	163818	DEFLECTOR-EXHAUST	1
4	163830	PLATE-CAP	1
5	MSC6100-30	SCREW-SHCS-M6X1.00X3	4
6	163827	PLATE-WEAR	2
7	149819	WEAR GUIDE	2
8	163848	FRAME CAP-MACHINING	1
9	105814	O-RING-1.929X.098	1
10	163820	BUMPER-HEAD VALVE	1
11	163844	SPRING-HEAD VALVE	1
12	163822	O-RING-2.487X.103XNB	2
13	163821	LOWER BODY-HEAD VALV	1
14	163823	SEAL-HEAD VALVE	1
15	163845	SEAL-FRAME/CAP	1
16	851606-S	O-RING-1.850X.210	1
17	163921	ASSEMBLY-PISTON/DRIV	1
18	163824	SLEEVE-CYLINDER	1
19	175520	SEAL-CHECK	1
20	163855	RING-CYLINDER SLEEVE	1
21	108718	O-RING-3.484X.139	1
22	89673	O-RING	1
23	163856	SEAL-END CAP	1
24	163843	END CAP-PAINT	1
25	T50118	WASHER-PLAIN	4
26	MSC5080-20	SCREW-SOC HD. CAP M5	4
27	166781	SPRING-UPPER TRIP	1

COPYRIGHT© 2005. All Rights Reserved.

Parts list, pricing, and availability subject to change. Please visit www.dewaltservicenet.com for current parts information.

Parts List for F21PL Type 0

Item Number	Part Number	Description	Qty Required
28	171432	LABEL-MAGNESIUM	1
29	171127	FRAME-OVERMOLD	1
30	107231	BUMPER-DRIVE	1
31	MCN-KIT3	KIT-METAL CONNECTOR	1
32	163900	ARM-UPPER CONTACT	1
33	MSC4070-16	SCREW-SHCS-M4X0.7X16	1
34	163903	BUSHING-TRIP COVER	1
35	163923	NOSE-F21PL	1
36	166772	SPRING-CONTACT ARM	1
37	108224	CASTING-HOUSING CONT	1
38	142941	ARM-LOWER CONTACT	1
39	121072	ASSEMBLY-TRIP FOOT	1
40	115230	SPRING-HOUSING	1
41	166777	CASTING-PLUNGER	1
42	MSC8125-30	SCREW-SHCS M8X30	4
43	854004	WASHER-RUBBER-7	1
44	163877	PAWL	1
45	163878	SPRING-CHECK PAWL	1
46	149882	PIN-CHECK PAWL	1
47	163883	GUIDE-ARM	1
48	SEQ7	KIT-SEQUENTIAL TRIP	1
49	CNTK5	KIT-CONTACT TRIP CON	1
50	100387	SPRING-COMPRESSION	1
51	TVA6	KIT-TRIGGER VALVE	1
52	171335	LABEL-WARNING-METAL	1
53	108562	SCREW-TRIGGER PIVOT	2
54	MHE3050-100	NUT-NYLON M3X.50	2

COPYRIGHT© 2005. All Rights Reserved.

Parts list, pricing, and availability subject to change. Please visit www.dewaltservicenet.com for current parts information.

Parts List for F21PL Type 0

Item Number	Part Number	Description	Qty Required
55	100298	PIN-SPIRAL M3X30	1
56	MPP030020	PIN-SPIRAL M3X20MM	1
57	123859	BUSHING-FLANGED ISOL	1
58	MPW6.2	WASHER.SPECIAL	1
59	158612	LABEL-WARNING	1
60	159722	LABEL-N88RH-2MCN FAS	1
61	MHE6100-100	NUT-ESN M6X1	3
62	163860	BRACKET	1
63	121406	LINER-NAIL GUIDE	1
64	166797	O-RING-.056X.060 NBR	1
65	104981	LABEL-WARNING	1
66	100261	SCREW	1
67	121472	SPACER-PUSHER LATCH	1
68	166782	MAGAZINE-PAD PRINT-F	1
69	166778	LATCH-PUSHER	1
70	120927	LABEL-SENSOR SMALL (1
71	163912	ASSEMBLY-END CAP	1
72	163867	ROD-GUIDE	1
73	120878	SPRING- PUSHER LATCH	1
74	MPW4	WASHER-PWN-M4	1
75	MSB6100-12	SCREW-SBHCS-M6X1.00X	2
76	121407	PIN-SPECIAL	1
77	MHE4070-100	ELASTIC STOP NUT-M4	2
78	163901	PUSHER	1
79	115143	SPRING-CONSTANT FORC	1
80	163902	HANDLE-PUSHER	1
81	121052	SCREW-SHCS-M4X0.70X2	2

COPYRIGHT© 2005. All Rights Reserved.

Parts list, pricing, and availability subject to change. Please visit www.dewaltservicenet.com for current parts information.

Parts List for F21PL Type 0

Item Number	Part Number	Description	Qty Required
82	112630	SHIELD-DUST	1
83	112631	SPRING-CLIP	1
84	121071	CLIP-TRIP FOOT	1
85	121070	FOOT-TRIP	1
86	163858	PLUG-EXHAUST	1
88	MSC6100-35	SCREW-SHCS-M6X1.00X3	1
89	171354	ASSEMBLY-UTILITY HOO	1
90	171342	WASHER-UTILITY HOOK	1
91	171338	COVER-TRIP	1
92	UB3811.2	PIN- SPIROL - 5/32X3	1
93	171340	MOUNT-UTILITY HOOK	1
94	171341	SPRING-UTILITY HOOK	1
95	171339	HOOK-UTILITY	1
800	100653	LUBE (2CC)	1
800	100679	LUBE (1LB.CAN)	1
876	N89ORK	O-RING KIT	1

COPYRIGHT© 2005. All Rights Reserved.

Parts list, pricing, and availability subject to change. Please visit www.dewaltservicenet.com for current parts information.